



E-Tech[®]

by Franklin Electric

SUBMERSIBLE PUMPS 4", MOTORS AND ACCESSORIES

50Hz



INDEX

VS Series Stainless Steel Submersible Pumps for 4" deep wells and larger	4
General Product Curves 4"	5
Material Table 4"	5

Table of Hydraulic Performance

VS 1	6
VS 2	6
VS 4	6
VS 6	6
VS 8	6
VS 10	7
VS 15	7

Technical Data and Performance Curves 50Hz

VS 1	10
VS 2	12
VS 4	14
VS 6	16
VS 8	18
VS 10	20
VS 15	22

Section and list of main components

VS 1 - 2 - 4 - 6 - 8 - 10 - 15	24
--------------------------------	----

Submersible Motors Product

4" Encapsulated Motors - 4" Super Stainless 1 Phase 3-wire	26
4" Encapsulated Motors - 4" Super Stainless 3 Phase	28

Accessories

Motor Control - Submonitor Motor Protection	30
Motor Control - SubStartSC® Single phase Submersible Motor Starter	31
Termination Kit 4"	32
Double Plug Lead for Termination Kit	32
Corrosion Protection 4"	32
Motor Filling Kit	32
Surge Arrestor	32



VS Series Stainless Steel Submersible Pumps for 4" deep wells and larger

Characteristics and Hydraulic Performances

50 Hz

APPLICATIONS

- Municipal water works, fountains and waste water
- Water distribution and pressure boosting
- Irrigation and sprinkler systems, water treatment plants, filtration and reverse osmosis
- Industrial cooling and processing
- Mining industry, drainage and dewatering
- Fire-fighting equipment
- Water supply to and from tanks, reservoir and wells
- Lifting and distribution of a wide range of liquids
- Autoclave and cistern charge and discharge
- Turf and landscape
- Greenhouses and nurseries
- Residential and farm wells and drainage
- Food industry
- General industry

FEATURES

- Compact, reliable and suited to operate in horizontal position
- Built-in check valve to protect the pump against water hammer risk
- Floating impellers to grant a better performance and longer life for the pump against abrasion
- The hydraulic design is such to enhance the overall efficiency thus reducing energy consumption and making the pumping systems more cost effective

SPECIFICATIONS

- Capacities up to 24 m³/h at 50Hz
- Pumped liquid: chemically and mechanically non aggressive
- Water temperature range: from 0°C to 40°C
- Maximum allowable amount of sand 25 gr/m³, solid dimension max 2mm
- Maximum pump diameter (including cable guard): 95mm
- Outlet diameter: 1 ¼" VS1-2-4-6, 2" VS8-10-15
- 25 Bar (250 m) at 50Hz
- Rotation: counter clockwise when looking into the discharge
- Motor adapter in compliance with NEMA standard
- Pump can work continuously in vertical or horizontal position
- Motors: see section Submersible Motors Product Overview

AVAILABLE OPTIONS

- Motor-pump : Cooling shroud, Suction shroud

PUMP IDENTIFICATION CODE

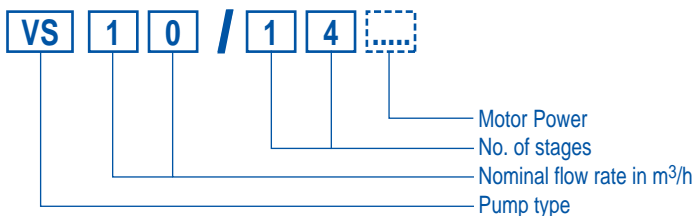

00117028 10/2010

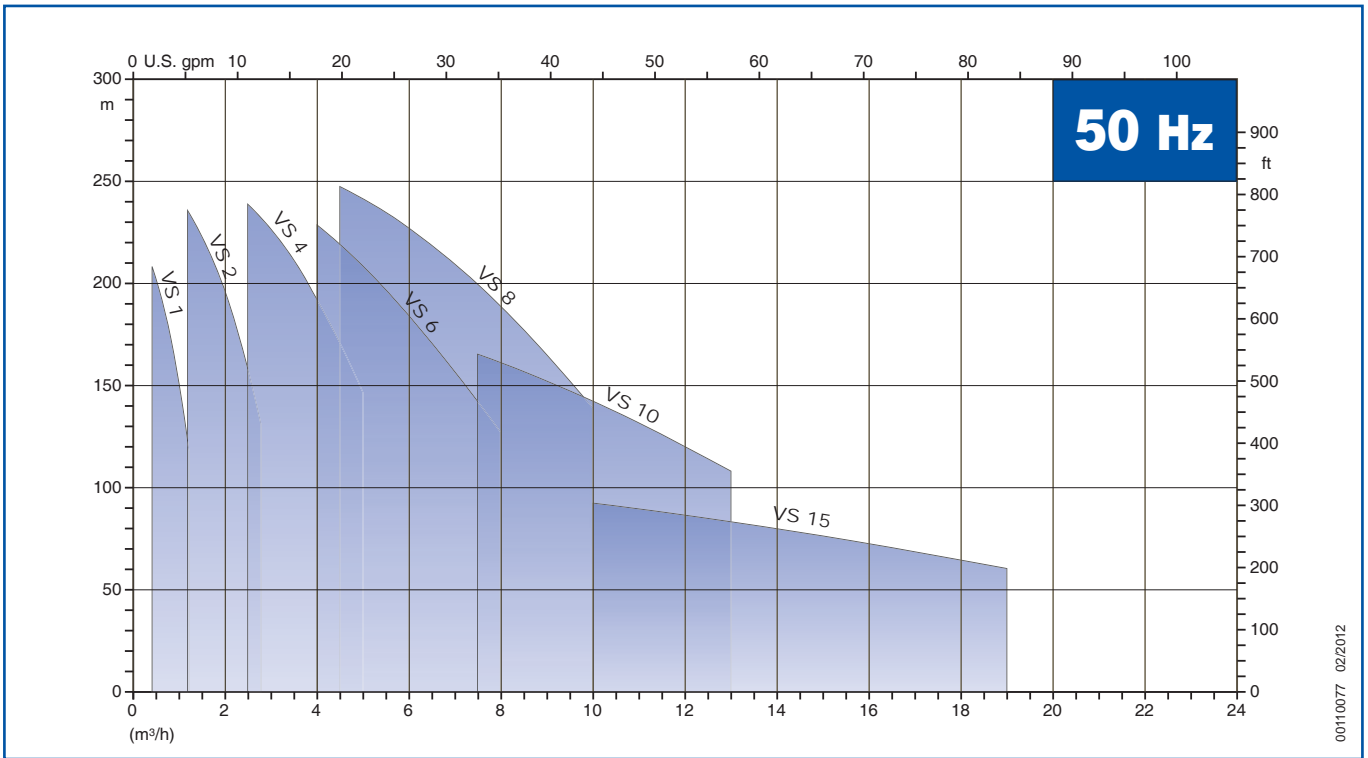

00110077 02/2012

MATERIAL IN CONTACT WITH THE LIQUID

Pos.	PARTS DESCRIPTIONS	MATERIAL		
		Type	AISI	DIN / EN
10.00	Discharge head and and screws	Stainless steel	304	1.4301
10.01	Valve	Resine	-	-
10.02	O-ring	Nitrile Rubber	-	-
10.04	Valve support	Resine	-	-
20.00	Outer case	Stainless steel	304	1.4301
20.01	Suction Strainer	Stainless steel	304	1.4301
20.02	Cable guard and screws	Resine	-	-
20.05	Motor adapter	Resine	-	-
30.00	Pump shaft	Stainless steel	304	1.4301
30.01	Coupling	Stainless steel	304	1.4301
30.04	Upper journal sleeve	Stainless steel	304	1.4301
30.05	Screw and washer	Stainless steel	304	1.4301
30.07	Lower spacer	Stainless steel	304	1.4301
30.08	Upper spacer	Polycarbonate	-	-
40.00	Diffusers	Technopolymer	-	-
40.01	Secondary bearing bush	Resine	-	-
40.04	Bearing bush	Resine	-	-
40.05	Upper bearin guide	Resine	-	-
40.09	Stage housing	Stainless steel	304	1.4301
50.00	Impeller	Polycarbonate	-	-

VS1/2/4

TABLE OF HYDRAULIC PERFORMANCES AT 50Hz

PUMP TYPE	RATED POWER		Q = DELIVERY																		
	kW	HP	m ³ /h	0	0,3	0,6	0,9	1,2	1,5	1,8	2,1	2,4	2,7	3,0	3,3	3,6	4,2	4,8	5,4	6,0	7,0
			l/sec	0	0,08	0,17	0,25	0,33	0,42	0,50	0,58	0,67	0,75	0,83	0,92	1,00	1,17	1,33	1,50	1,67	1,94
H = TOTAL HEAD METERS COLUMN OF WATER [m]																					
VS 1/10	0,37	0,5	68	59	53	45	35	18													
VS 1/13	0,37	0,5	83	71	64	54	39	20													
VS 1/19	0,55	0,75	118	104	94	80	57	30													
VS 1/26	0,75	1	156	142	126	105	75	41													
VS 1/38	1,1	1,5	241	215	193	162	117	63													
VS 2/5	0,37	0,5	34				30	29	27	25	22	18	14	10							
VS 2/7	0,37	0,5	42				43	40	37	35	30	25	20	14							
VS 2/10	0,55	0,75	67				60	57	54	49	43	36	28	20							
VS 2/14	0,75	1	94				85	80	75	68	60	50	39	27							
VS 2/20	1,1	1,5	133				120	114	107	97	86	72	56	40							
VS 2/27	1,5	2	189				164	154	145	132	115	97	75	53							
VS 2/39	2,2	3	259				235	222	209	190	167	140	110	75							
VS 4/4	0,37	0,5	25						23	23	22	21	20	20	19	17	14	11	8		
VS 4/7	0,55	0,75	45						40	40	39	27	36	35	34	29	25	20	14		
VS 4/10	0,75	1	64						57	56	55	54	52	49	47	42	35	28	19		
VS 4/14	1,1	1,5	89						80	78	77	75	72	68	65	59	50	40	26		
VS 4/18	1,5	2	114						104	101	99	95	93	88	85	80	64	50	34		
VS 4/27	2,2	3	170						154	151	148	145	139	133	127	114	95	75	50		
VS 4/32	3	4	222						183	180	175	170	165	157	150	135	113	90	60		
VS 4/40	3,7	5	252						229	225	220	223	212	196	189	166	141	113	75		
VS 4/44	3,7	5	278						252	247	242	235	226	217	207	185	155	124	83		

VS 6/8

TABLE OF HYDRAULIC PERFORMANCES AT 50Hz

PUMP TYPE	RATED POWER		Q = DELIVERY																		
	kW	HP	m ³ /h	0	2,7	3,0	3,3	3,6	4,2	4,8	5,4	6,0	7,0	7,2	8,0	8,4	9,0	9,6	10,1	10,8	12,0
			l/sec	0	0,75	0,83	0,92	1,00	1,17	1,33	1,50	1,67	1,94	2,00	2,22	2,33	2,50	2,67	2,81	3,00	3,33
H = TOTAL HEAD METERS COLUMN OF WATER [m]																					
VS 6/6	0,75	1	36	33	33	32	32	31	30	28	26	23	22	18	16	13					
VS 6/9	1,1	1,5	53	49	48	48	47	46	44	41	39	33	32	25	23	17					
VS 6/13	1,5	2	77	74	73	72	71	69	66	63	60	52	50	43	38	32					
VS 6/19	2,2	3	110	105	104	103	102	99	95	90	85	74	72	60	52	41					
VS 6/26	3	4	150	143	141	139	137	132	126	120	110	94	90	73	63	49					
VS 6/31	3,7	5	185	177	175	172	169	164	155	146	136	115	110	90	76	58					
VS 6/34	4	5,5	200	192	189	185	182	175	165	155	145	123	118	95	83	64					
VS 6/45	5,5	7,5	269	257	253	249	245	235	223	208	191	160	155	128	113	93					
VS 8/4	0,75	1	25				24	24	23	23	22	20	20	18	17	15	14	12	10		
VS 8/6	1,1	1,5	38				36	36	35	35	33	30	30	27	26	24	21	19	15		
VS 8/9	1,5	2	57				50	53	52	50	49	45	45	40	39	35	32	28	24		
VS 8/14	2,2	3	88				85	83	80	78	75	70	68	62	60	54	48	43	35		
VS 8/18	3	4	113				108	106	110	101	92	90	88	80	75	70	61	55	46		
VS 8/23	3,7	5	150				141	138	140	131	126	117	115	105	100	91	82	75	64		
VS 8/32	5,5	7,5	206				193	189	185	179	173	160	158	145	140	127	117	106	90		
VS 8/42	7,5	10	273				252	250	245	237	227	210	206	189	181	165	150	135	116		

VS 10

TABLE OF HYDRAULIC PERFORMANCES AT 50Hz

PUMP TYPE	RATED POWER		Q = DELIVERY																		
			m³/h	0	6,0	7,0	7,2	8,0	8,4	9,0	9,6	10,1	10,8	12,0	13,0	13,2	14,0	14,4	15,6	16,0	17,0
			l/sec	0	1,67	1,94	2,00	2,22	2,33	2,50	2,67	2,81	3,00	3,33	3,61	3,67	3,89	4,00	4,33	4,44	4,72
		H = TOTAL HEAD METERS COLUMN OF WATER [m]																			
kW	HP																				
VS 10/5	1,1	1,5	30	26	25	25	24	23	22	21	20	18	16	14	13	12	11	8	7	5	
VS 10/7	1,5	2	42	37	36	34	33	33	31	30	28	27	23	20	20	17	16	12	11	8	
VS 10/11	2,2	3	64	56	54	53	51	50	47	45	43	40	35	30	29	25	23	18	15	11	
VS 10/14	3	4	82	73	69	68	66	65	61	58	56	53	45	40	38	32	32	24	21	20	
VS 10/18	4	5,5	107	97	93	92	89	87	83	80	77	72	63	55	54	48	45	36	33	26	
VS 10/25	5,5	7,5	150	135	130	128	124	121	117	112	108	103	91	82	80	71	68	55	50	39	
VS 10/32	7,5	10	194	175	168	167	160	157	152	145	140	133	120	108	105	95	91	74	68	55	

VS 15

TABLE OF HYDRAULIC PERFORMANCES AT 50Hz

PUMP TYPE	RATED POWER		Q = DELIVERY																		
			m³/h	0	9	10	11	12	13	14	15	16	17	18	19	20	21	22	23	24	25
			l/sec	0	2,5	2,8	3,1	3,3	3,6	3,9	4,2	4,4	4,7	5,0	5,3	5,6	5,8	6,1	6,4	6,7	7,0
		H = TOTAL HEAD METERS COLUMN OF WATER [m]																			
kW	HP																				
VS 15/8	2,2	3	46	36	35	33	32	30	29	27	26	25	23	21	20	18	15	13	10		
VS 15/10	3	4	58	45	43	41	40	38	36	34	33	30	29	27	25	22	19	16	13		
VS 15/12	4	5,5	69	54	52	50	48	45	43	41	39	37	35	32	30	26	23	20	16		
VS 15/16	5,5	7,5	92	73	69	66	63	60	58	55	52	49	46	43	39	35	31	26	21		
VS 15/21	7,5	10	121	95	91	87	84	80	75	72	68	64	60	56	51	46	40	35	27		



VS Series Stainless Steel Submersible Pumps for 4" deep wells and larger

Technical Data and Performance Curves

50 Hz

Pumps with Encapsulated Motor

Pump model type	Motor			Dimensions [mm]					Weight [Kg]				
	Type	kW	HP	Lt		L2		L1	Motor		Pump	Total	
				1~	3~	1~	3~		1~	3~		1~	3~
VS 1/10	E4	0,37	0,5	596	582	228	214	368	7,8	7,2	4,0	11,8	11,2
VS 1/13	E4	0,37	0,5	648	634	228	214	420	7,8	7,2	4,5	12,3	11,7
VS 1/19	E4	0,55	0,75	776	756	248	228	528	8,7	7,7	5,6	16,4	13,3
VS 1/26	E4	0,75	1	962	928	282	248	680	10,0	8,7	7,4	17,4	16,1
VS 1/38	E4	1,1	1,5	1259,5	1203,5	338,5	282,5	921	12,6	10,2	10,0	22,6	20,2

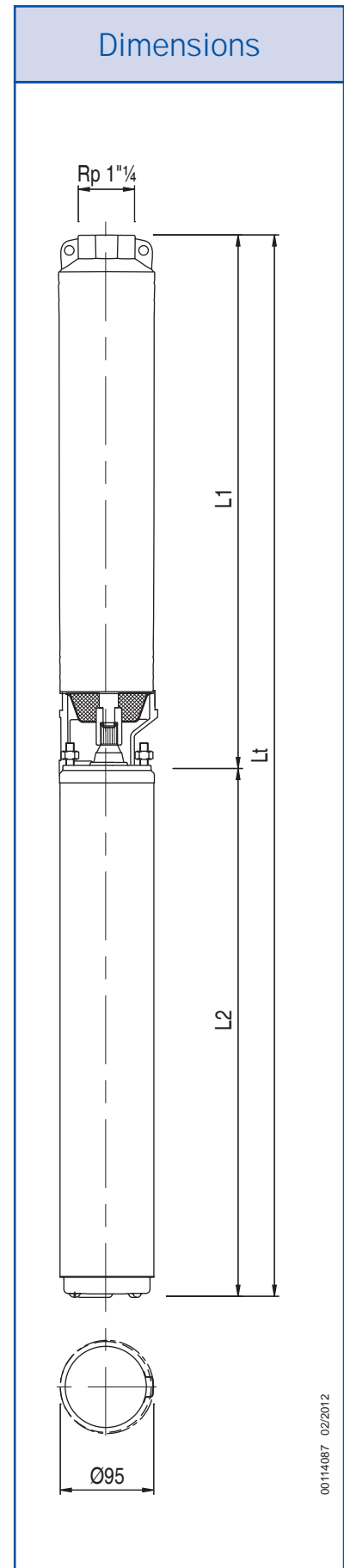

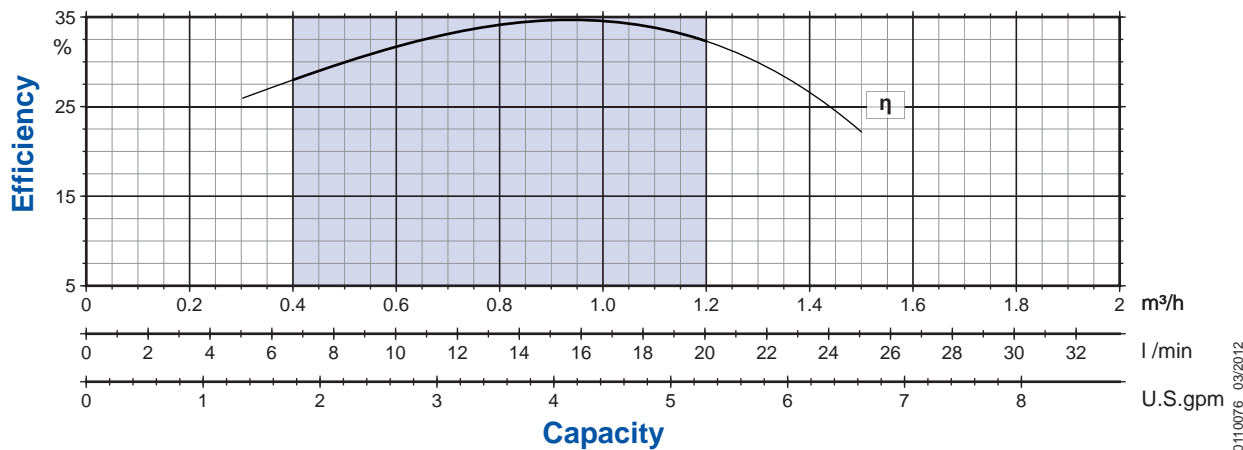
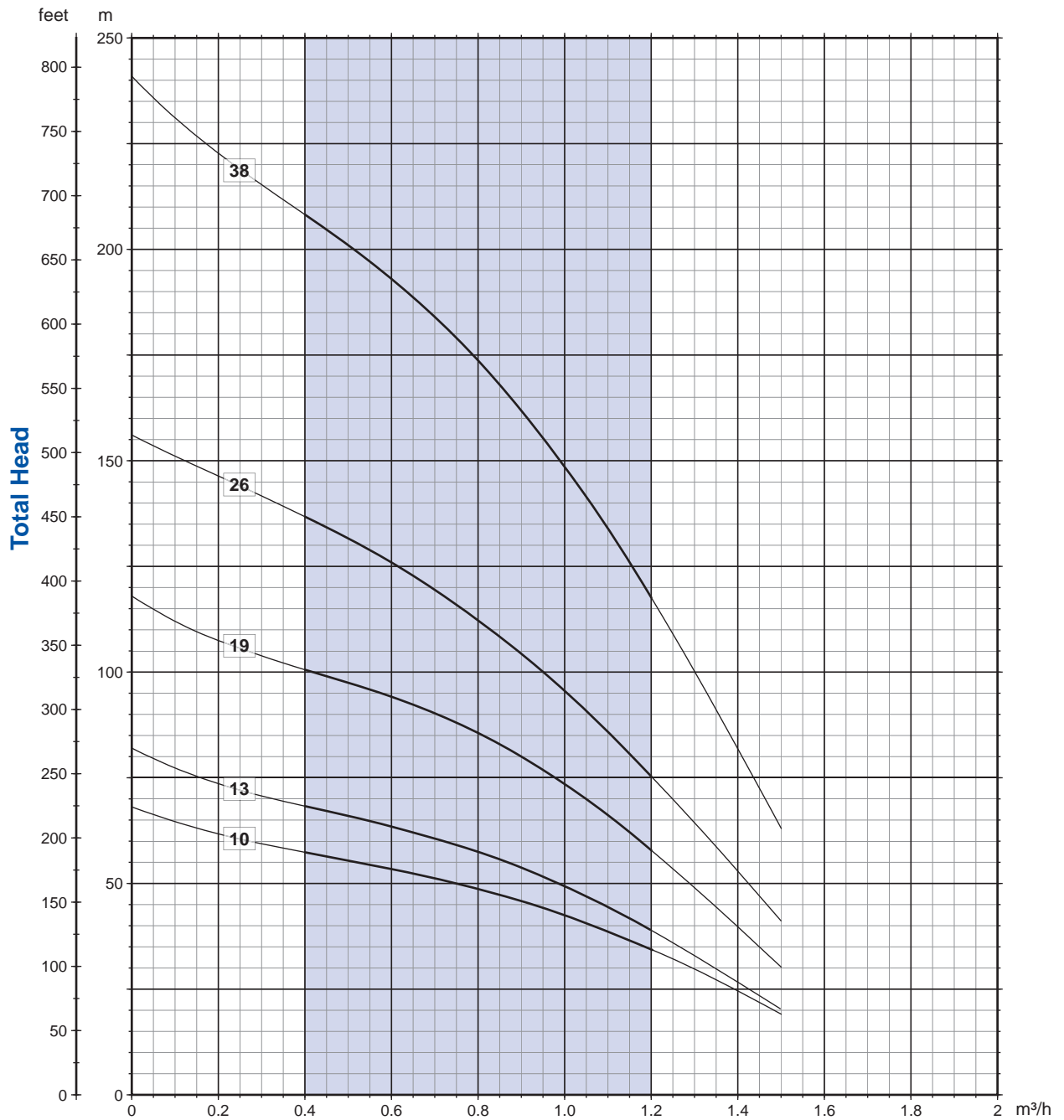

00110076 03/2012

Pumps with Encapsulated Motor

Pump model type	Motor			Dimensions [mm]					Weight [Kg]				
	Type	kW	HP	Lt		L2		L1	Motor		Pump	Total	
				1~	3~	1~	3~		1~	3~		1~	3~
VS 2/5	E4	0,37	0,5	506	492	228	214	278	7,8	7,2	3,0	10,8	10,2
VS 2/7	E4	0,37	0,5	542	528	228	214	314	7,8	7,2	3,4	11,2	10,6
VS 2/10	E4	0,55	0,75	615	595	248	228	367	8,7	7,7	4,0	12,7	11,7
VS 2/14	E4	0,75	1	720,5	686	282,5	248	438	10,0	8,7	4,6	14,6	13,3
VS 2/20	E4	1,1	1,5	880,5	824,5	338,5	282,5	542	12,6	10,2	5,6	18,2	15,8
VS 2/27	E4	1,5	2	1044,5	1001,5	349,5	306,5	695	13,0	11,2	7,1	20,1	18,3
VS 2/39	E4	2,2	3	1370,5	1272,5	436,5	338,5	934	16,9	12,6	9,4	26,3	22,0

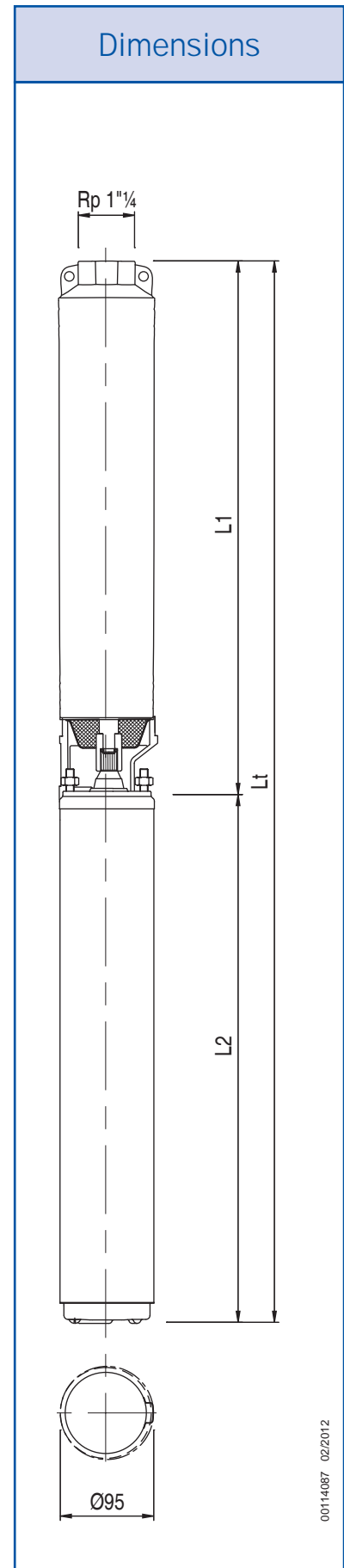

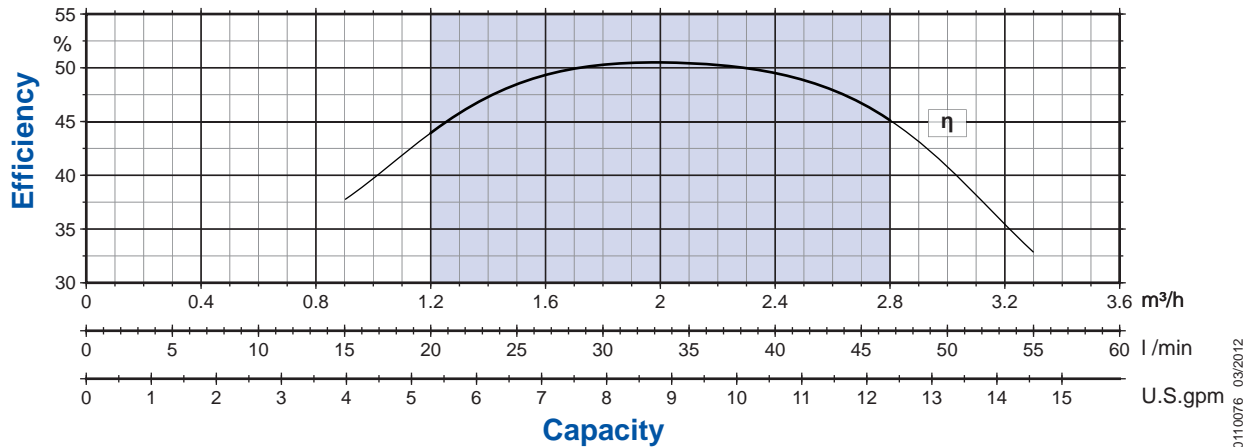
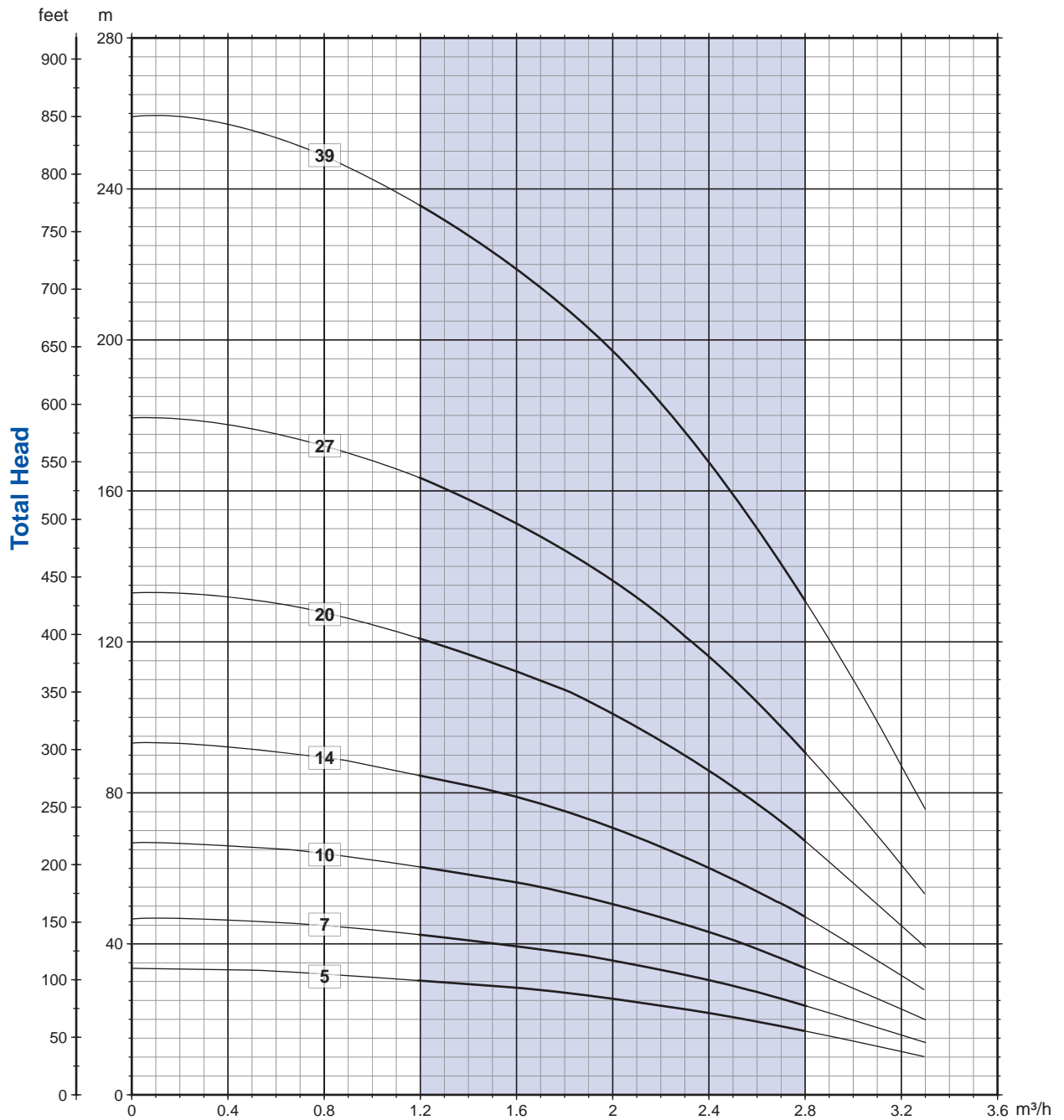

Pumps with Encapsulated Motor

Pump model type	Motor			Dimensions [mm]					Weight [Kg]				
	Type	kW	HP	Lt		L2		L1	Motor		Pump	Total	
				1~	3~	1~	3~		1~	3~		1~	3~
VS 4/4	E4	0,37	0,5	506	492	228	214	278	7,8	7,2	2,9	10,7	10,1
VS 4/7	E4	0,55	0,75	591	571	248	228	343	8,7	7,7	3,5	12,2	11,2
VS 4/10	E4	0,75	1	693,5	659	282,5	248	411	10,0	8,7	4,2	14,2	12,9
VS 4/14	E4	1,1	1,5	836,5	780,5	338,5	282,5	498	12,6	10,2	5,1	17,7	15,3
VS 4/18	E4	1,5	2	937,5	894,5	349,5	306,5	588	13,0	11,2	5,9	18,9	17,1
VS 4/27	E4	2,2	3	1220,5	1122,5	436,5	338,5	784	16,9	12,6	7,2	24,1	19,8
VS 4/32	E4	3	4	-	1346,5	-	393,5	953	-	15,0	9,2	-	24,2
VS 4/40	E4	3,7	5	-	1648	-	520	1128	-	19,1	10,5	-	29,6
VS 4/44	E4	3,7	5	-	1739	-	520	1219	-	19,1	11,8	-	30,9

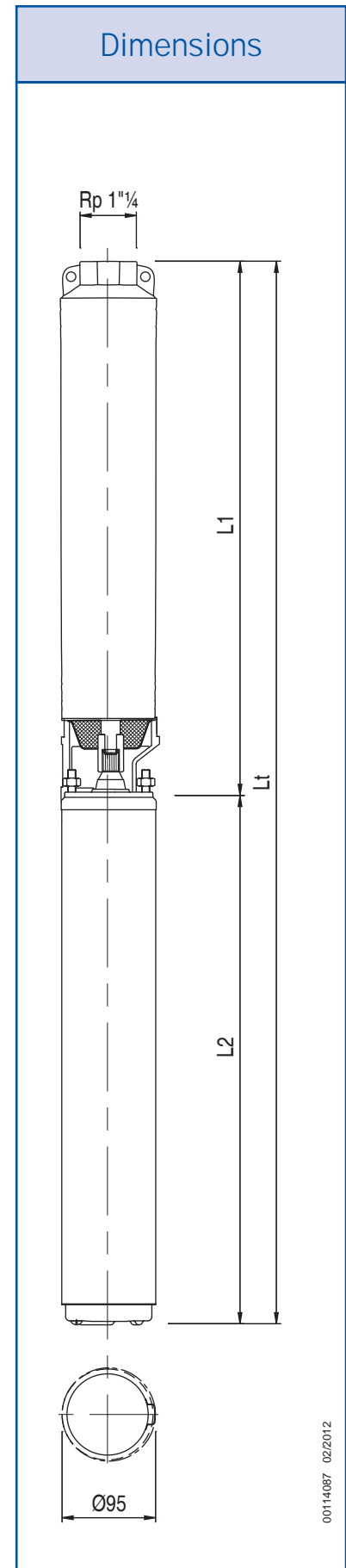

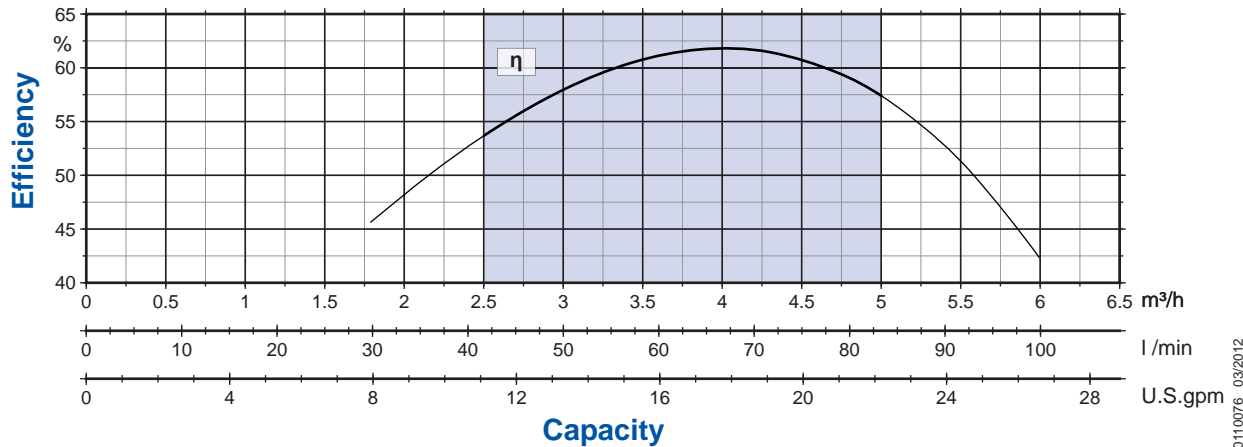
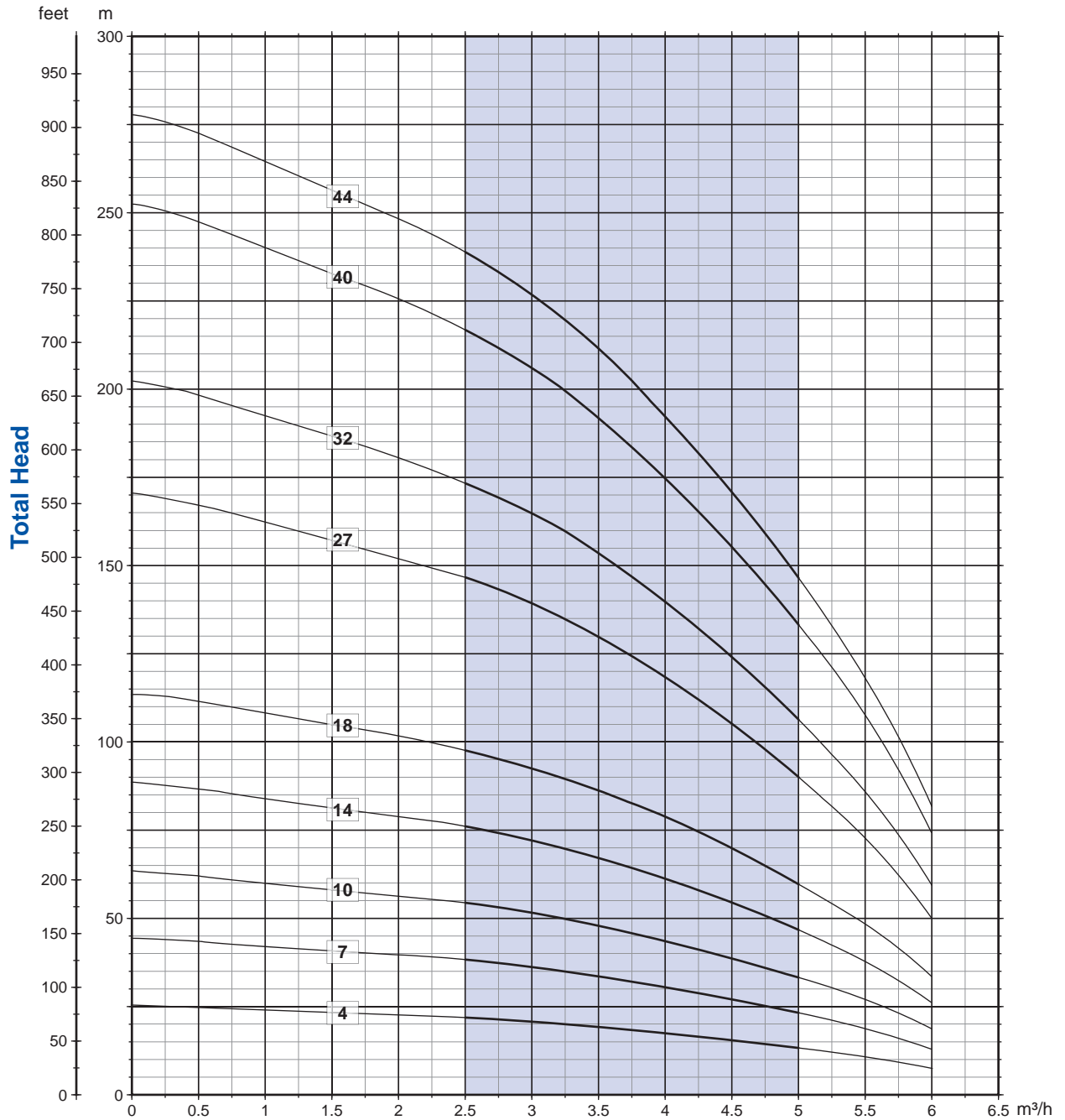

Pumps with Encapsulated Motor

Pump model type	Motor			Dimensions [mm]					Weight [Kg]				
	Type	kW	HP	Lt		L2		L1	Motor		Pump	Total	
				1~	3~	1~	3~		1~	3~		1~	3~
VS 6/6	E4	0,75	1	653,5	619	282,5	248	371	10,0	8,7	3,2	13,2	11,9
VS 6/9	E4	1,1	1,5	799,5	743,5	338,5	282,5	461	12,6	10,2	4,0	16,6	14,2
VS 6/13	E4	1,5	2	961,5	918,5	349,5	306,5	612	13,0	11,2	5,3	18,3	16,5
VS 6/19	E4	2,2	3	1257,5	1159,5	436,5	338,5	821	16,9	12,6	7,3	24,2	19,9
VS 6/26	E4	3	4	-	1424,5	-	393,5	1031	-	15,0	8,7	-	23,7
VS 6/31	E4	3,7	5	-	1732	-	520	1212	-	19,1	10,2	-	29,3
VS 6/34	E4	4	5,5	-	1846	-	543	1303	-	20,0	10,9	-	30,9
VS 6/45	E4	5,5	7,5	-	2283,5	-	652,5	1631	-	26,6	14,1	-	40,7

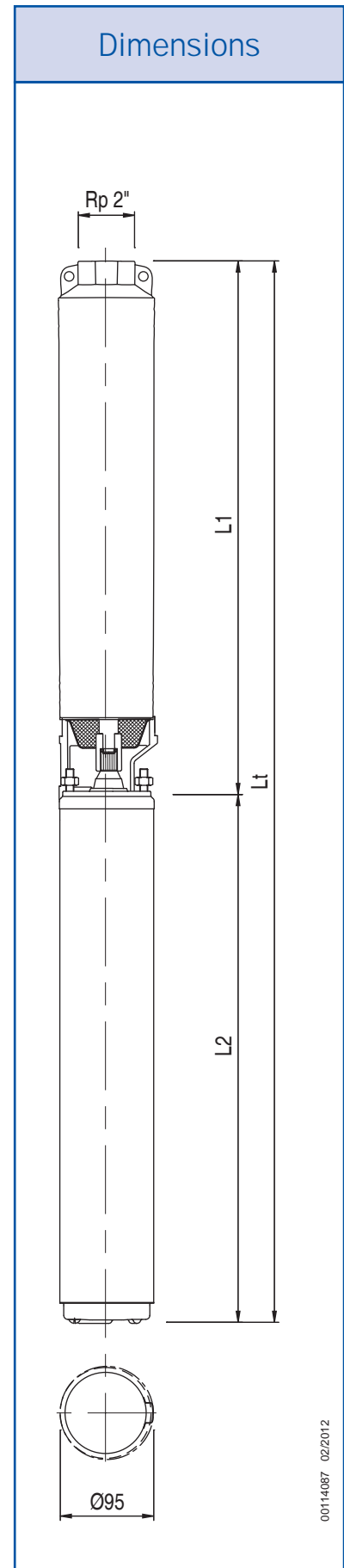

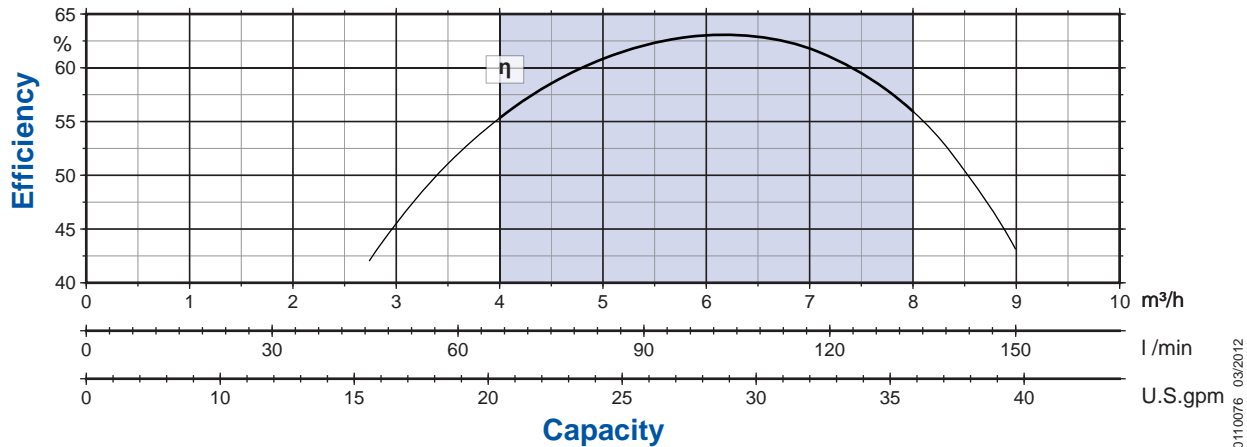
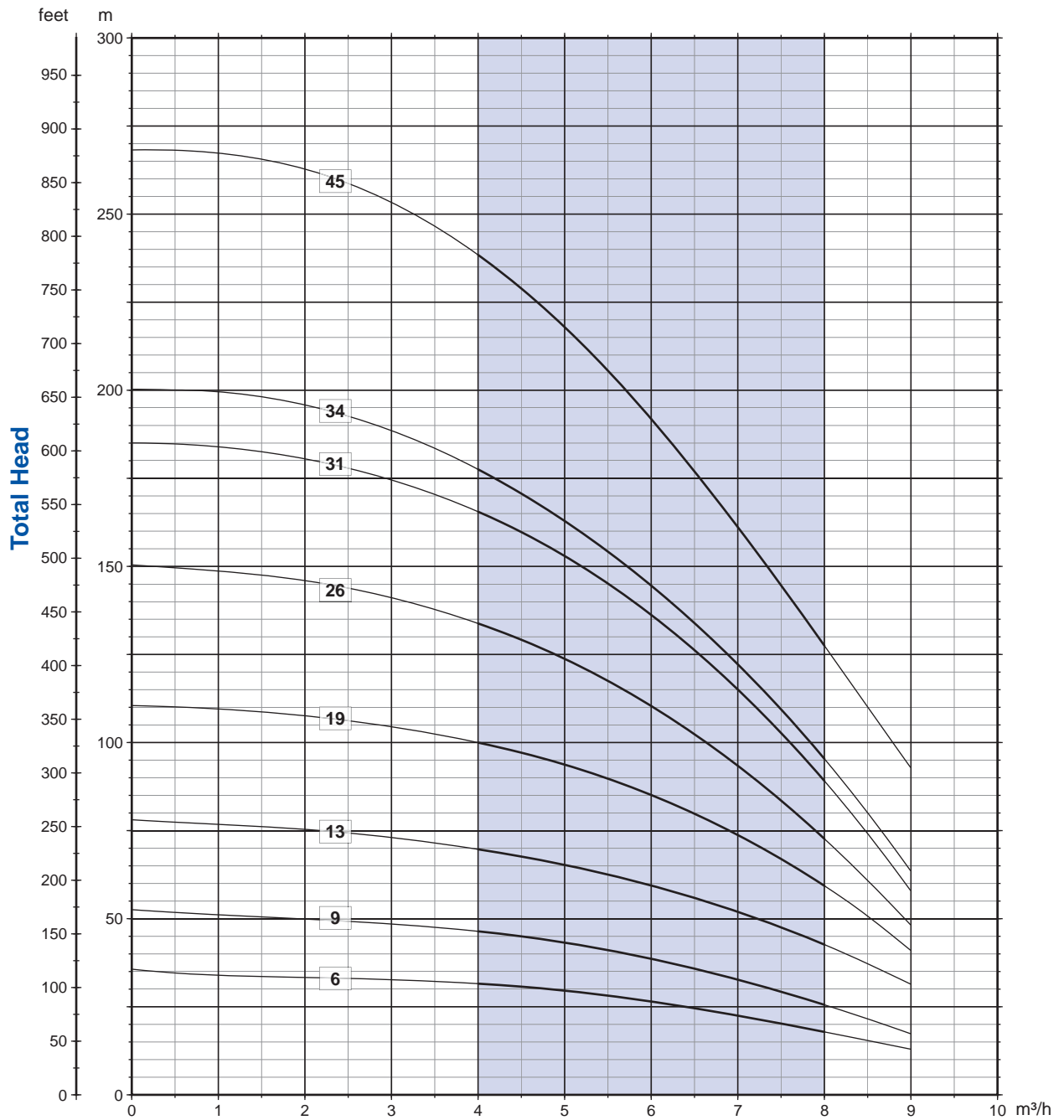

Pumps with Encapsulated Motor

Pump model type	Motor			Dimensions [mm]					Weight [Kg]				
	Type	kW	HP	Lt		L2		L1	Motor		Pump	Total	
				1~	3~	1~	3~		1~	3~		1~	3~
VS 8/4	E4	0,75	1	593,5	559	282,5	248	311	10,0	8,7	2,9	12,9	11,6
VS 8/6	E4	1,1	1,5	709,5	653,5	338,5	282,5	371	12,6	10,2	3,2	15,8	13,4
VS 8/9	E4	1,5	2	810,5	767,5	349,5	306,5	461	13,0	11,2	4,0	17,0	15,2
VS 8/14	E4	2,2	3	1079,5	981,5	436,5	338,5	643	16,9	12,6	5,4	22,3	18,0
VS 8/18	E4	3	4	-	1186,5	-	393,5	793	-	15,0	6,6	-	21,6
VS 8/23	E4	3,7	5	-	1463	-	520	943	-	19,1	7,7	-	26,8
VS 8/32	E4	5,5	7,5	-	1897,5	-	652,5	1245	-	26,6	10,1	-	36,7
VS 8/42	E4	7,5	10	-	2306,5	-	730,5	1576	-	30,6	12,8	-	42,4

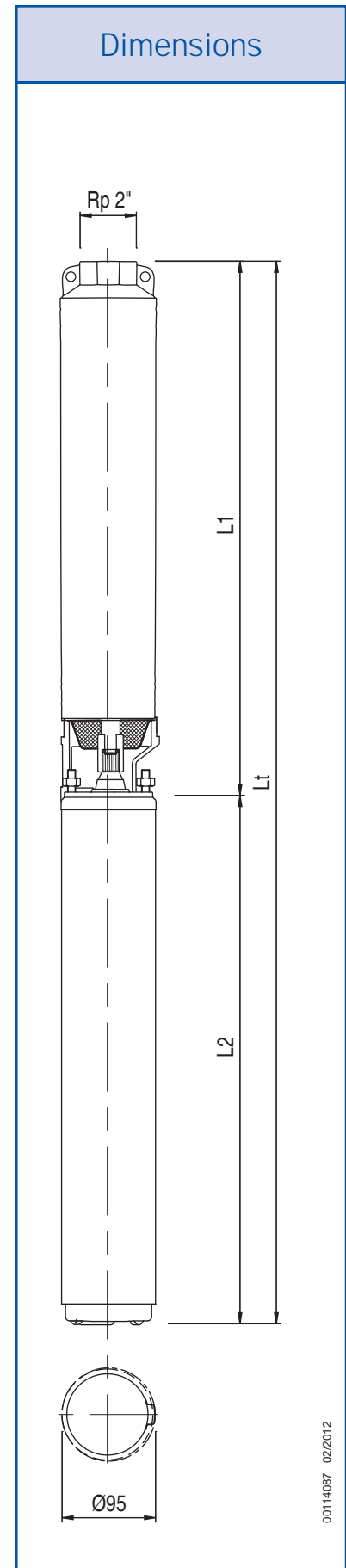

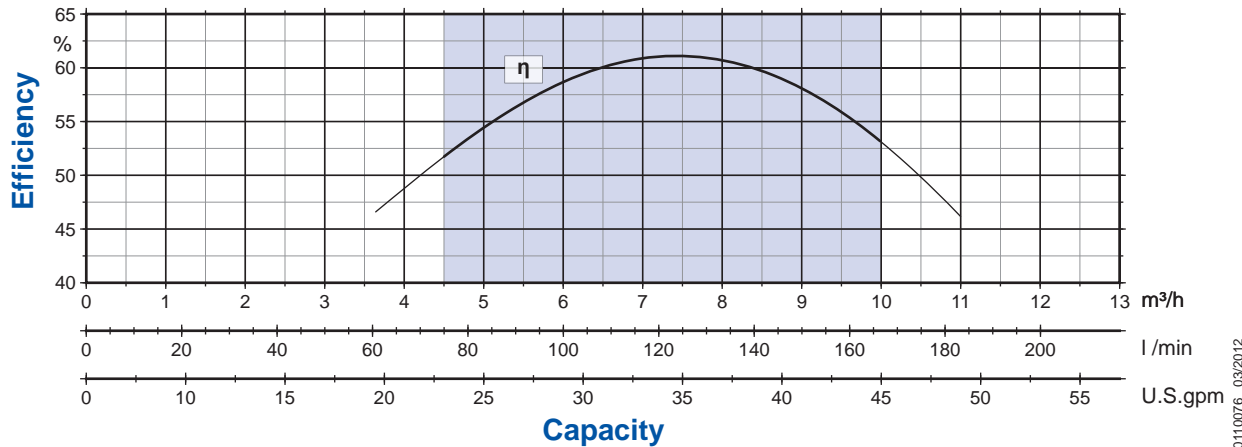
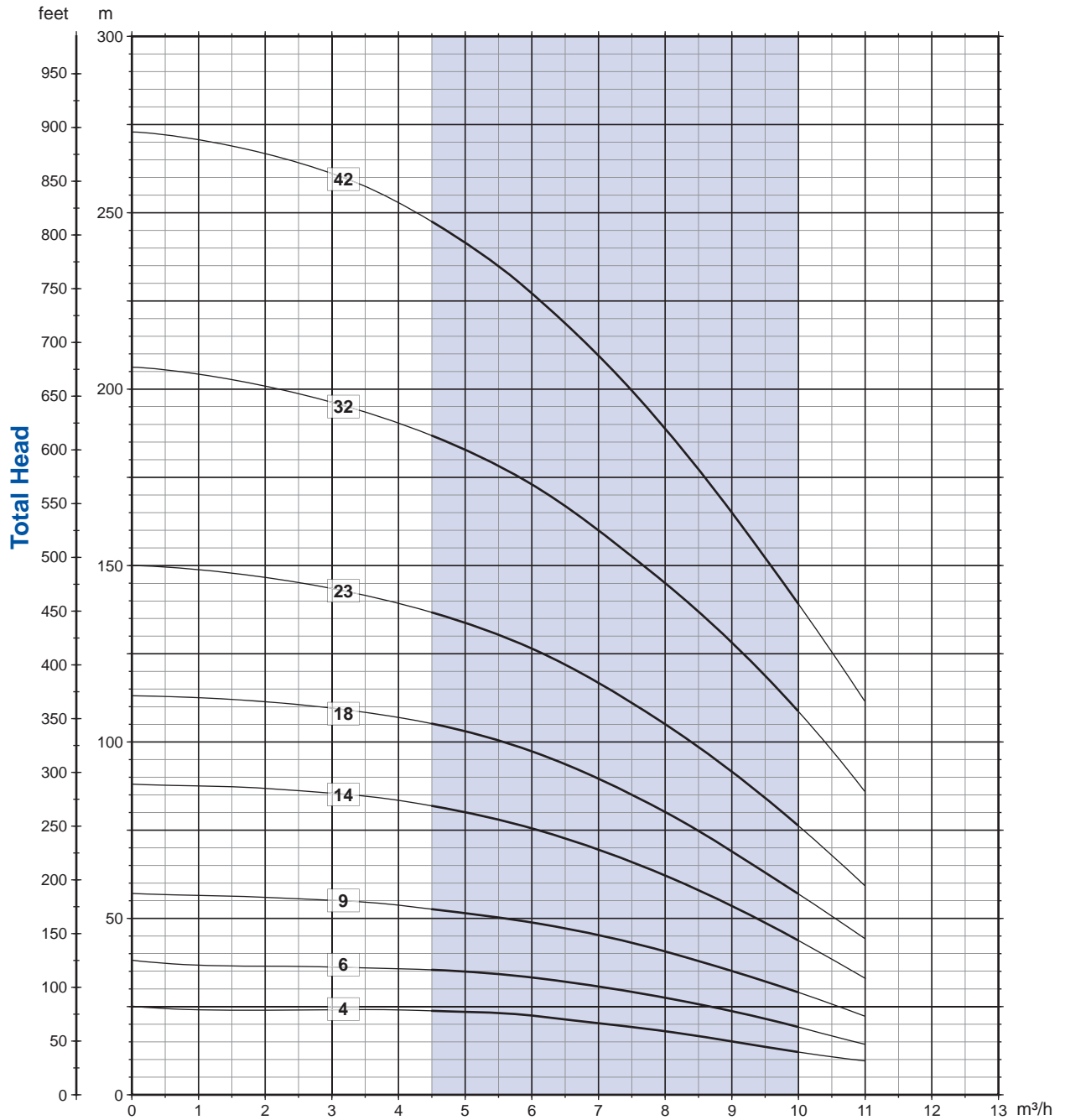

Pumps with Encapsulated Motor

Pump model type	Motor			Dimensions [mm]					Weight [Kg]				
	Type	kW	HP	Lt		L2		L1	Motor		Pump	Total	
				1~	3~	1~	3~		1~	3~		1~	3~
VS 10/5	E4	1,1	1,5	778,5	722,5	338,5	282,5	440	12,6	10,2	3,7	16,3	13,9
VS 10/7	E4	1,5	2	890,5	847,5	349,5	306,5	541	13,0	11,2	4,4	17,4	15,6
VS 10/11	E4	2,2	3	1209,5	111,5	436,5	338,5	773	16,9	12,6	6,3	23,2	18,9
VS 10/14	E4	3	4	-	1316,5	-	393,5	923	-	15,0	7,6	-	22,6
VS 10/18	E4	4	5,5	-	1696	-	543	1153	-	20,0	9,4	-	29,4
VS 10/25	E4	5,5	7,5	-	2188,5	-	652,5	1536	-	26,6	12,4	-	39,0
VS 10/32	E4	7,5	10	-	2648,5	-	730,5	1918	-	30,6	15,8	-	46,4

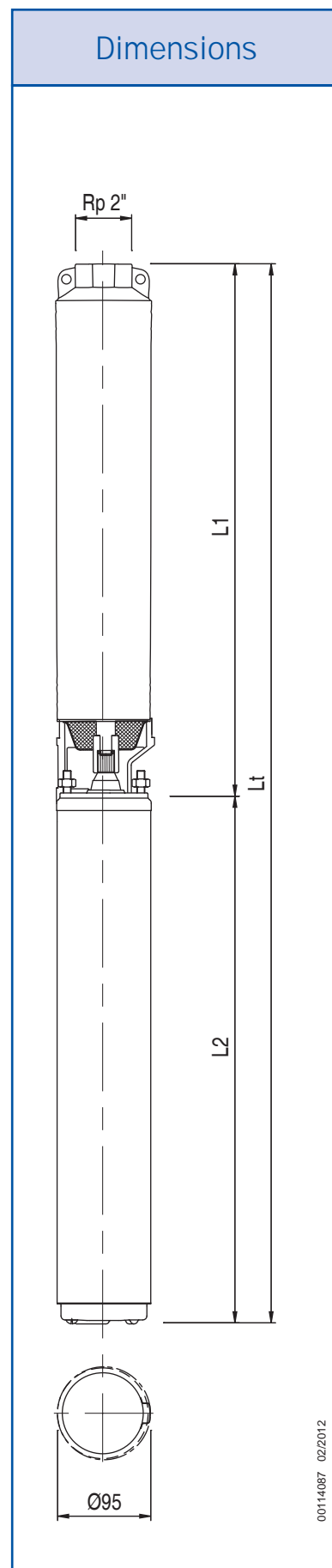

00114087 02/2012

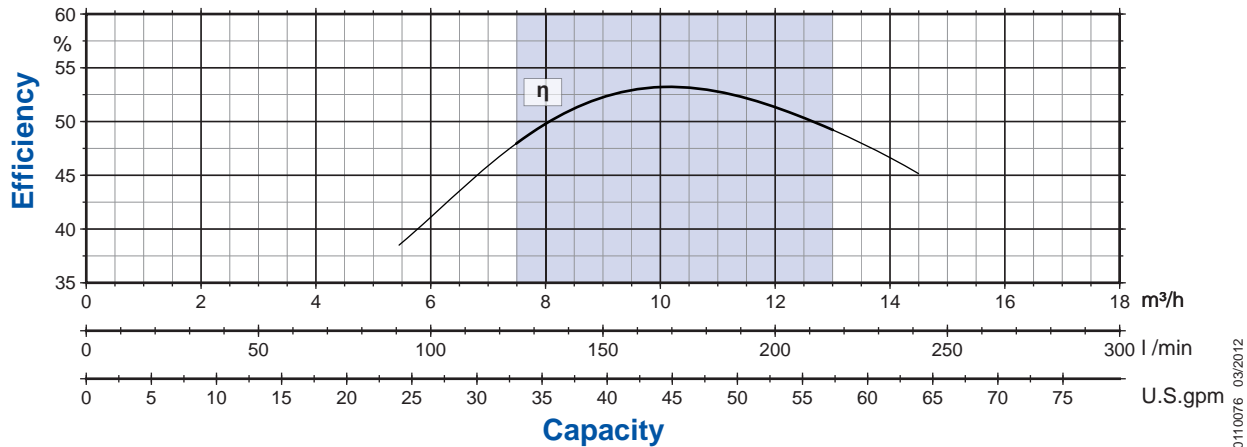
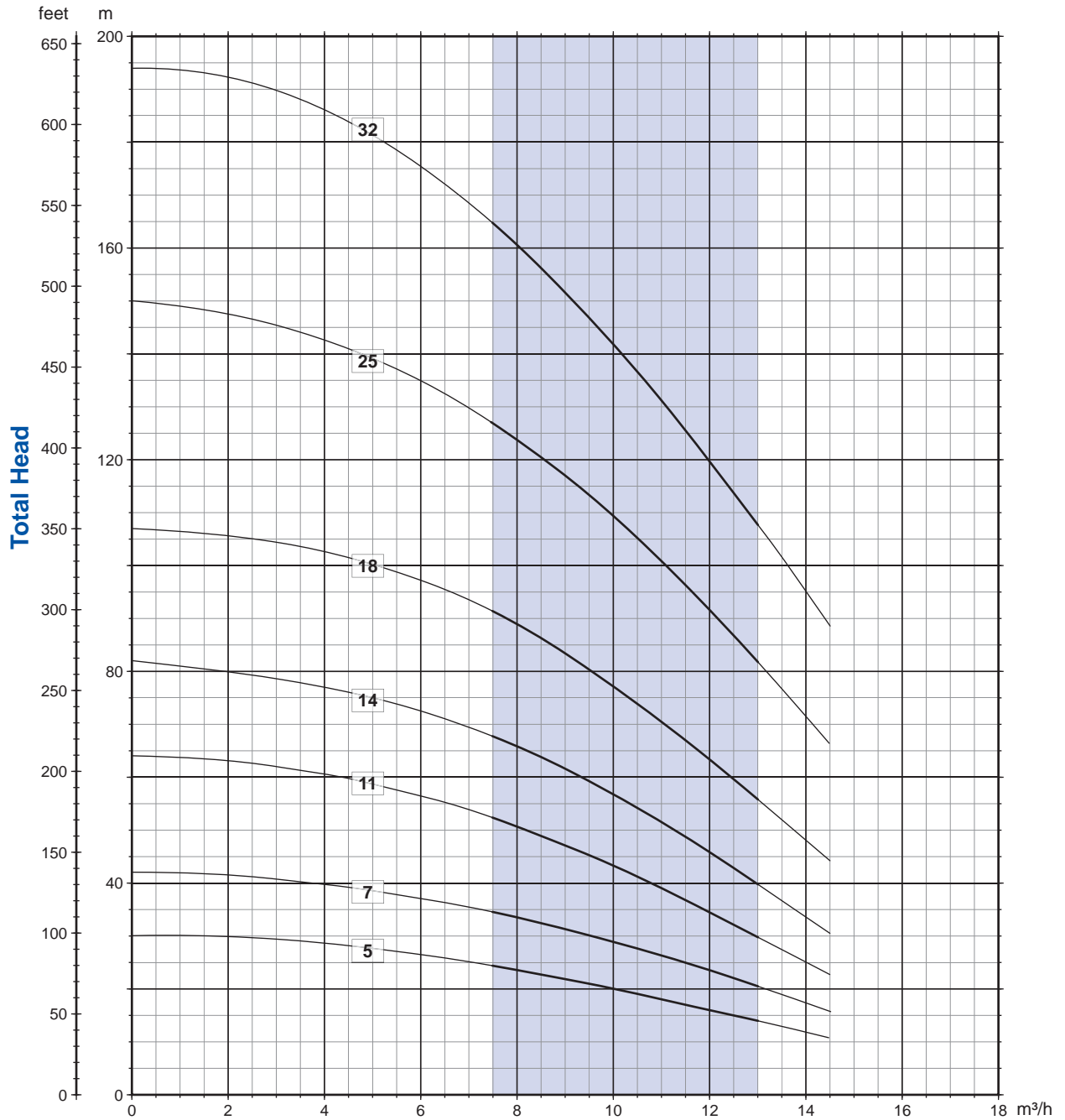

00110076 03/2012

Pumps with Encapsulated Motor

Pump model type	Motor			Dimensions [mm]					Weight [Kg]				
	Type	kW	HP	Lt		L2		L1	Motor		Pump	Total	
				1~	3~	1~	3~		1~	3~		1~	3~
VS 15/8	E4	2,2	3	1122,5	1024,5	436,5	338,5	686	16,9	12,6	5,4	22,3	18,0
VS 15/10	E4	3	4	-	1226,5	-	393,5	833	-	15,0	6,4	-	21,4
VS 15/12	E4	4	5,5	-	1515	-	543	981	-	20,0	7,4	-	27,4
VS 15/16	E4	5,5	7,5	-	1927,5	-	652,5	1275	-	26,6	9,5	-	36,1
VS 15/21	E4	7,5	10	-	2373,5	-	730,5	1643	-	30,6	12,1	-	42,7

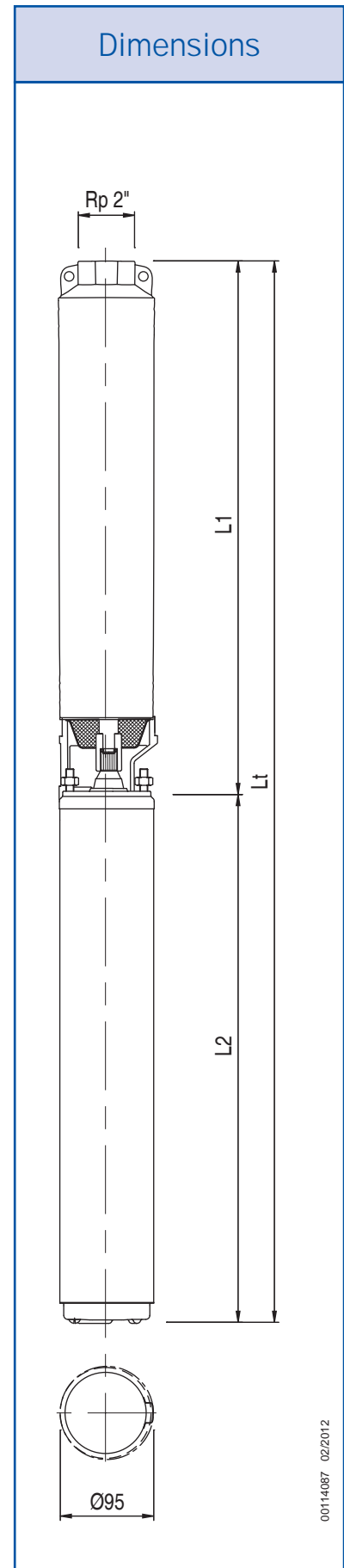

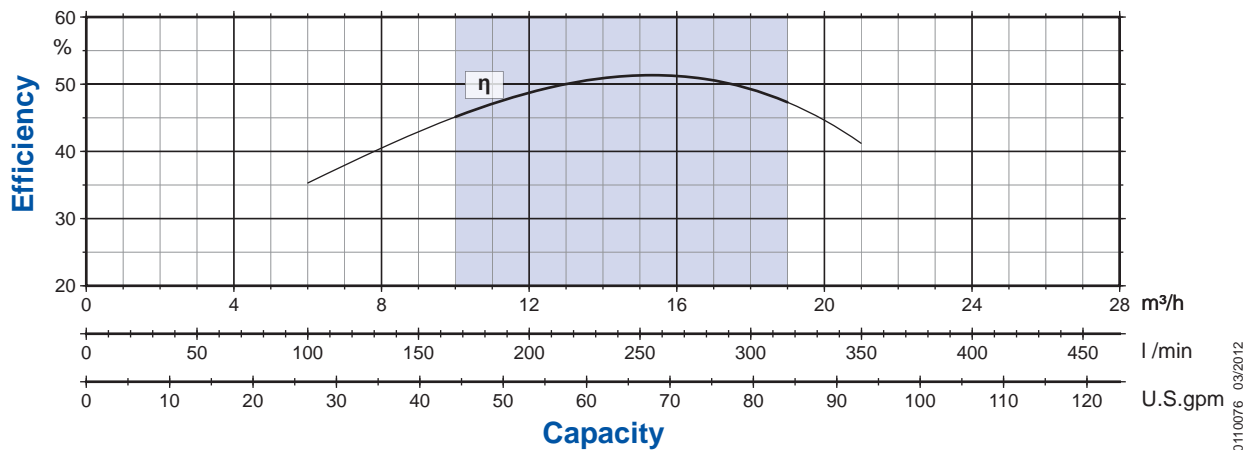
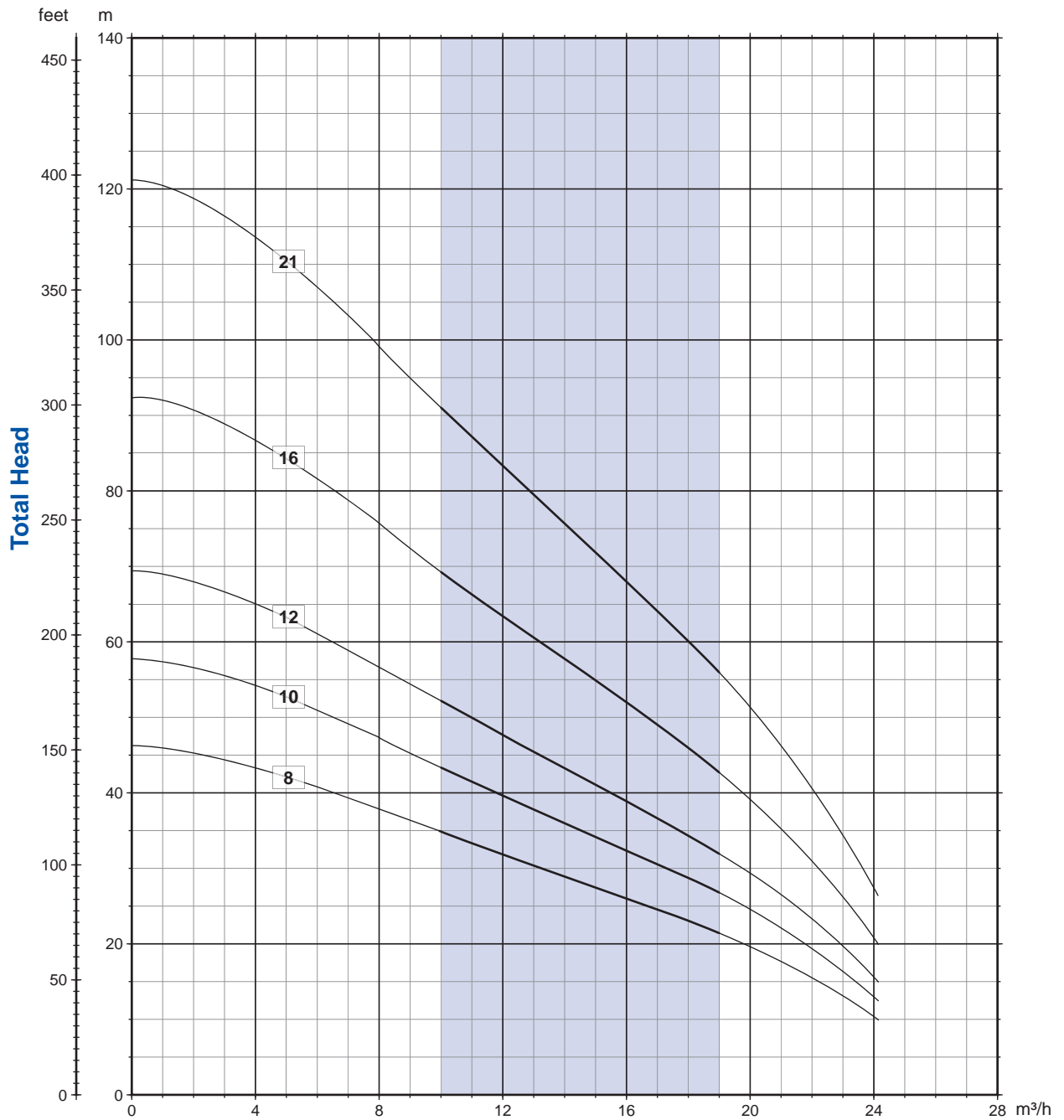

Section and List of Main Components

VS 1/2/4/6/8/10/15

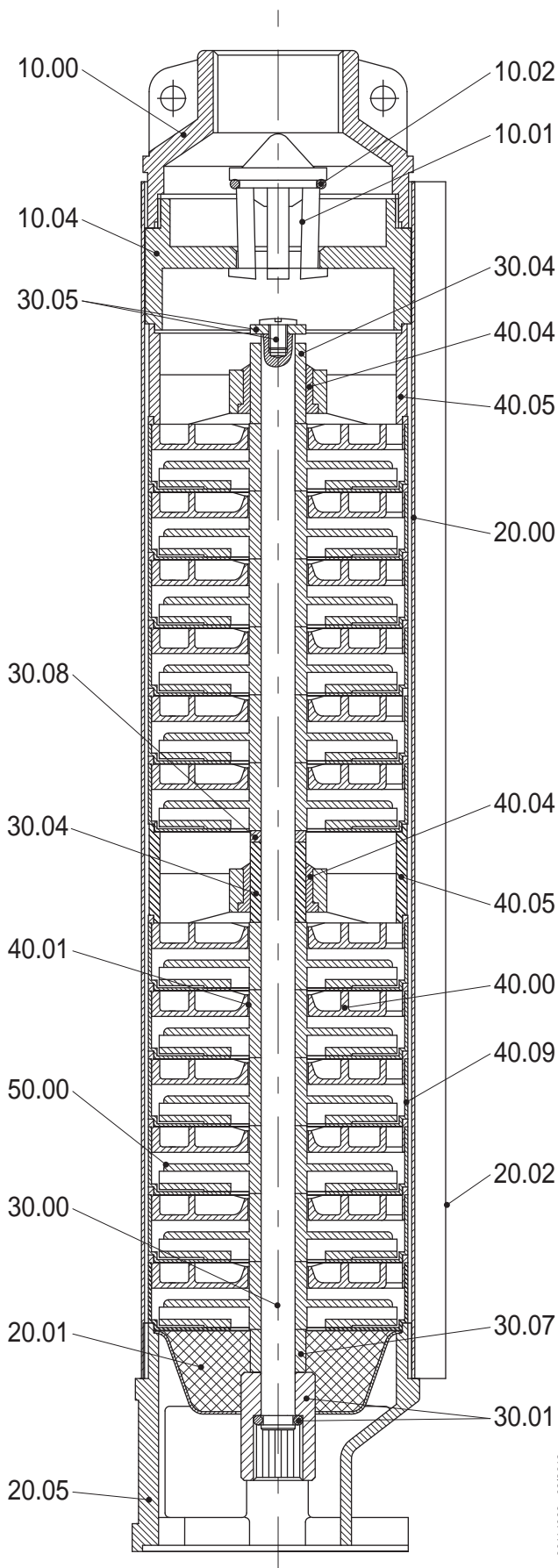

Ref. N.	Description
1000	Discharge head
1001	Valve
1002	O-ring
1004	Valve support
2000	Outer case
2001	Suction strainer
2002	Cable guard and screws
2005	Motor adapter
3000	Pump shaft
3001	Coupling
3004	Upper / Intermediate journal sleeve
3005	Screw and washer
3007	Lower spacer
3008	Upper spacer
4000	Diffusers
4001	Secondary bearing bush
4004	Bearing bush
4005	Upper / Intermediate bearing guide
4009	Stage housing
5000	Impeller

00114086 02/2012

Submersible Motors Product Overview

4" Encapsulated Motors

4" Super Stainless Single Phase 3-wire

SUBMERSIBLE MOTORS

Franklin Electric 4" encapsulated 3-wire capacitor single phase Motors, manufactured in ISO 9001 certified facilities, are built for dependable operation in 4" diameter or larger water wells.

Together with Franklin Electric Control Boxes, they offer you a maintenance free long life operation by high starting torque and included motor protection.

The motor is filled with a special FES93 fluid, providing frost protection down to -40°C storage temperature. A special diaphragm ensures pressure compensation inside the motor.

FEATURES

- Hermetically sealed stator. Anti track, self healing stator resin prevents motor burn out
- High efficiency electrical design (low operation cost, cooler winding temperature)
- Removable "Water Bloc™" lead connector
- Cable material according to drinking water regulations (KTW approved)
- Water lubricated radial and thrust bearings
- All motors prefilled and 100% tested.
Non contaminating, FES93- filled design
- For use with Franklin Electric control box
- Offer highest starting torque of all single phase motors

SPECIFICATIONS

- 0,37 - 2,2kW
- 4" NEMA flange
- Rotation: CCW facing shaft end
- Degree of protection: IP68
- Insulation: Cl. B
- Rated ambient temp.: 30°C
- Cooling flow: Motors 2,2 kW and larger: min. 8 cm/s
- Starts/h: 20
- Mounting: vertical/horizontal
- Voltage tolerance: +6% / -10% U_N
- Motor protection: included Franklin Electric Control Boxes

AVAILABLE OPTIONS

- Motor cable VDE / KTW approved (1,5m; special lengths available)
- Motors with factory- installed lead in Single Packing
- Complete 316SS Motor with SiC seal
- Built-in lightning arrestor



Performance table at ~2850 rpm

Single-Phase 4" Encapsulated Motors 3 wire / 230V

P_N	Thrust	n_N	I_N	I_A	η	$\cos \varphi$	T_N	T_A	L	Weight	
[kW]	[HP]	F [N]	[min ⁻¹]	[A]	[A]	[%]	[Nm]	[Nm]	[mm]	[kg]	
0,37	0,5	3000	2870	4,0	13,7	56	0,74	1,2	2,0	228,2	7,8
0,55	0,75	3000	2870	5,9	21,6	56	0,73	1,8	3,2	248,2	8,7
0,75	1	3000	2870	7,3	27,8	61	0,76	2,5	4,2	282,6	10,0
1,1	1,5	3000	2885	8,6	41,2	68	0,84	3,7	6,8	338,6	12,6
1,5	2	3000	2875	10,4	53,3	71	0,88	4,9	9,5	349,6	13,0
2,2	3	4000	2885	15,3	74,5	73	0,88	7,3	15,0	436,6	16,9
		6500*	2885	15,3	74,5	73	0,88	7,3	15,0	520,2	21,3

* High Thrust Version

Dimensions

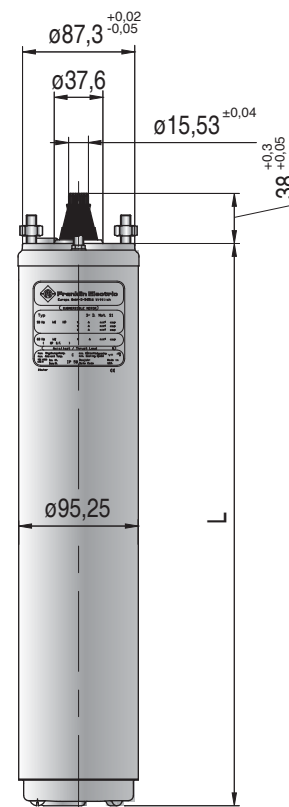

4" Encapsulated Motors

4" Super Stainless 3 Phase

SUBMERSIBLE MOTORS

These 4" encapsulated three phase motors, manufactured in ISO 9001 certified facilities, are built for dependable operation in 4" diameter or larger water wells. The motor offer you a maintenance free long life submersible pump application.

The motor is filled with a special FES93 fluid, providing frost protection down to -40°C storage temperature. A special diaphragm ensures pressure compensation inside the motor.

FEATURES

- Hermetically sealed stator. Anti track, self healing stator resin prevents motor burn out
- High efficiency electrical design (low operation cost, cooler winding temperature)
- Removable "Water Bloc™" lead connector
- Cable material according to drinking water regulations (KTW approved)
- Water lubricated radial and thrust bearings
- All motors prefilled and 100% tested.
Non contaminating, FES93- filled design

SPECIFICATIONS

- 0,37 - 7,5kW
- 4" NEMA flange
- Degree of protection: IP68
- Insulation: Cl. B
- Rated ambient temp.: 30°C
- Cooling flow: Motors 2,2 kW and larger: min. 8 cm/s
- Starts/h: 20
- Mounting: vertical/horizontal
- Voltage tolerance: 380-415V/50Hz, 460V/60Hz; -10% / +6% U_N [380-415V = (380-10%) – (415+6%)]
- Motor protection: Select thermal overloads according to EN 60947-4-1, Trip time <10 s at 5 x I_N

AVAILABLE OPTIONS

- Motor cable VDE / KTW approved (1,5m; 2,5m; special lengths available)
- Motors with factory- installed lead in Single Packing
- Special voltages on request
- YΔ - start (pos. of cables 90°) in motors 316SS on request
- Motor complete in AISI 316SS with SiC seal



Performance table at ~2850 rpm

Three-Phase 4" Encapsulated Motors 400V

P_N [kW]	Thrust [HP]	F [N]	n_N [min ⁻¹]	I_N [A]	I_A [A]	η [%]	$\cos \varphi$ [%]	T_N [Nm]	T_A [Nm]	L [mm]	Weight [kg]
0,37	0,5	3000	2870	1,1	5,41	66	0,74	1,22	3,00	214,2	7,2
0,55	0,75	3000	2870	1,6	7,4	68	0,74	1,82	4,20	228,2	7,7
0,75	1	3000	2865	2,0	7,0	70	0,77	2,49	6,70	248,2	8,7
1,1	1,5	3000	2850	2,8	16,0	74	0,78	3,67	11,33	282,6	10,2
1,5	2	3000	2855	3,9	20,7	73	0,78	5,00	14,10	306,6	11,2
2,2	3	3000	2845	5,5	29,8	75	0,77	7,37	22,0	338,6	12,6
		6500*	2845	5,5	29,8	75	0,77	7,37	22,0	422,2	15,0
3,0	4	3000	2845	7,5	42,0	76	0,77	10,06	31,93	393,6	15,0
		6500*	2845	7,5	42,0	76	0,77	10,06	31,93	477,2	17,0
3,7	5	6500*	2840	9,0	52,3	78	0,78	12,5	41,5	520,2	19,1
4,0	5,5	6500*	2840	9,9	57,0	78	0,77	13,4	44,0	543,2	20,0
5,5	7,5	6500*	2865	12,6	77,2	79	0,81	18,3	56,5	652,5	26,6
7,5	10	6500*	2855	17,1	99,3	79	0,81	25,1	73,1	730,5	30,6

* High Thrust Version

Dimensions

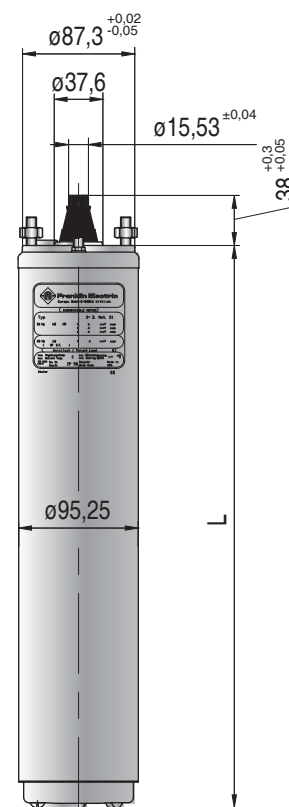

ACCESSORIES

Motor Control

SUBMONITOR MOTOR PROTECTION

The SubMonitor is designed to protect 3-phase pumps with horsepower ratings between 3 and 200 Hp. Current, voltage and motor temperature are monitored using three integrated current transformers. A digital display provides current and voltage readings for all three legs and allows the user to set up the SubMonitor quickly and easily. The SubMonitor is the latest innovation in 3-phase pump protection from Franklin Electric. Using state-of-the-art technology, the SubMonitor provides the ultimate protection for a pump and motor. There is simply no better way to protect a large 3-phase submersible pump investment than with a SubMonitor. It's the protection device that can sense overheating straight from the motor windings! And it is made by the world leader in submersible motors - Franklin Electric.



FEATURES

- Quick setup to monitor a motor, simply enter the Line Frequency (Hz), Line Voltage (volts), and Motor Service Factor Amp rating
- Digital display indicates voltage and current on all three legs at the same time, and fault messages are in easily understandable text
- Monitors - Under/Overload; Under/Overtorque; Current Unbalance; Overheated Motor (Subtrol Equipped); False Start (Chattering); Phase Reversal
- For motors with service factor amp ratings between 3 and 359 amps
- One unit covers the entire range from 190 to 600 Volts
- No need to make additional turns around the CT or add external CTs
- Password Protection Option
- DIN Rail Mounting Option
- Stores fault, setting changes, and pump run-time, that can be accessed through the display
- Detachable NEMA 3R display unit can be mounted on panel door
- UL 508 Listed

Model number

Premium Package	586 000 5100
Input Voltage	190 – 600 VAC
Frequency	60/50 Hz
Motor Service Factor Amps	3 to 359 Amps
Maximum Conductor Size Through Sensors	
Max. Diameter	0.920 in. (23 mm)
Trip Response	
Motor, Under / Overload, Under / Overtorque, Overheat Unbalance	3 seconds
Control Circuit Rating	1.5 Amp AC, up to 600 volts
Signal Circuit Rating	1 Amp AC, up to 250 volts (Incandescent: 100 watts max.)
Wiring Terminals	
Wire Gauge	#12 to #18 AWG
Tighten to	4.5 in-lbs
Weight (SubMonitor)	3.3 lbs/7.3 kg
Carton Size (Std. Unit)	7,75 in x 11,5 in x 6,75 in (19,7 cm x 29,2 cm x 17,1 cm)
Shipping Weight (Std. Unit)	3.5 Lbs./7.5 kg

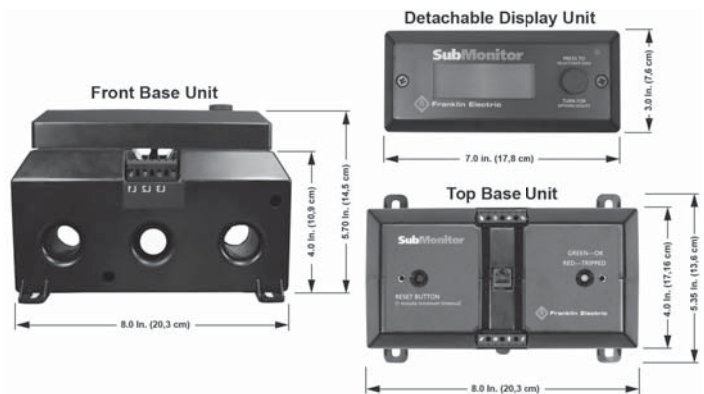

Motor Control

SubStartSC® Single phase Submersible Motor Starter

The SubStartSC® range covers all PSC motors from 0.25kW to 2.2kW for all voltages. Ergonomic design, attention to detail and unique features make the SubStartSC® motor starter range your first choice when considering submersible motor protection. In conjunction with Franklin Electric submersible motors you now have an tangible water system advantage resulting in ease of installation and reliable protection.

FEATURES

- Attention to detail – every aspect engineered for the application
- The complete package – The device is 100% compatible with the motor characteristics
- All in one name – Reliability backed by the leader in submersible motors



Ergonomically designed

Mounting	Easy wall mounting without destroying the protection rating of the enclosure.
Wiring	Sufficient space is provided for ease of wiring.
Enclosure	
Protection	IP54
Material	IN
Components	
ON/OFF switch	Illuminated integral ON/OFF switch for ease of power
Circuit breaker	Thermal circuit breaker for protection of the motor.
Capacitor	High quality motor run capacitor for long life
Terminal board	Terminal board suitable for ease of reliable connections
Cable glands	Cable glands to ensure IP54 rating

Technical Specifications

Mechanical	
Protection level	IP54
External dimensions	168 x 142 x 85mm
Weight	0,6 - 1,0 kg
Mounting	Wall mounting (mounting hardware provided)
Temperature	-5°C - +40°C
Humidity	50% at 55°C (without condensation)
Electrical	
Voltage	220 - 240V; - 1 / +10 %; 50Hz single phase
Current	16 A
Power	0,25 - 2,2 kW

Standards

IEC 60439-1

Submersible Motor Starter Specifications

Part Number ¹	Type ²	Motor rating (kW)	Nominal Current ³ (A)	Maximal expected current ⁴ (A)	Capacitor (µF) 450V ac
284 623 3510	SS025SC	0,25	2,5	8,4	12,5
284 624 3510	SS037SC	0,37	3,4	11,2	16
284 625 3510	SS055SC	0,55	4,3	16,1	20
284 626 3510	SS075SC	0,75	5,8	21,1	35
284 627 3510	SS110SC	1,10	8,6	31,5	40
284 628 3510	SS150SC	1,50	10,6	35,4	50
284 629 3510	SS220SC	2,20	16,0	54,2	70

NOTES:

1. Can be used with both 220-230V and 230-240V PSC motor ranges.
2. Type indicates motor power rating and motor type.
3. Nominal supply current at nominal voltage
4. Motor starting current under nominal conditions

Dimensions

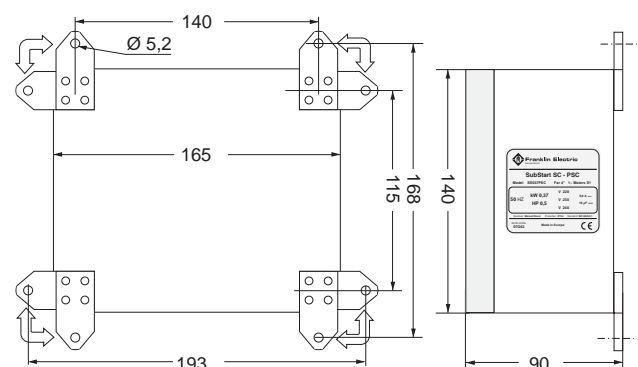

ACCESSORIES

Termination Kit 4"

This proven, sturdy solution is your choice of cable joining in temporary pump applications or when re-usage if the drop cable is desired. Furthermore, the flexibility and safety it provides for under field service conditions makes it the preferred choice over conventional, not breakable splicing kits.



Double Plug Lead for Termination Kit

- 2-wire / 3-wire
- 1,5m / 2,5m Lead length
- with / without Strain relief
- Max. current 16 Apms.
- KTW approved



Corrosion Protection 4"

APPLICATION

The sacrificial anode attaches to the bottom end bell of Franklin Electric 4" Super Stainless submersible motors. Since cast iron is more chemically active than the metals that make up the motor and pump, it is the cast iron that reacts to the corrosive elements in the water. This results in longer motor and pump life in aggressive/corrosive water conditions.



Motor Filling Kit

This kit offers all tools for control the level of the engine filling liquid and to fill up if necessary!

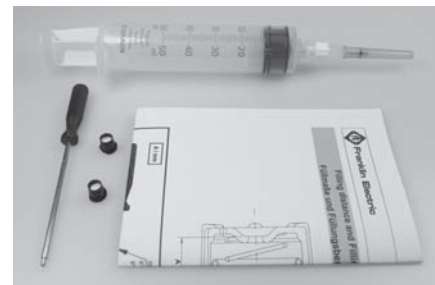

Surge Arrestor

APPLICATION

These surge arrestors or their equivalents are highly recommended for protecting submersible motors from a variety of commonly occurring high voltage spikes which can damage the motor insulation system and cause motor winding failure. These arrestors will not, as is true of any surge protection equipment, protect the motor from a direct lightning strike.





Vertical S.p.A.
via Asolo, 7
36031 Dueville (Vicenza) - Italy
Tel. +39 0444 361114
Fax +39 0444 365247
e-mail: sales@vertical.vi.it
www.etechpumps.com