

PMC "DOUBLE-CHANNEL"

Fixed installation pumps

► for sewage water



PERFORMANCE RANGE

- Flow rate up to **1600 l/min** (96 m³/h)
- Head up to **25 m**

APPLICATION LIMITS

- **10 m** maximum immersion depth with a sufficiently long power cable
- Maximum liquid temperature **+40 °C**
- Solids passage:
 - up to **Ø 50 mm** for PMC 15-20-30-40/50
 - up to **Ø 70 mm** for PMC 30-40/70
- Minimum immersion depth for continuous service:
 - **390 mm** for PMC 15-20-30-40/50
 - **440 mm** for PMC 30-40/70

CONSTRUCTION AND SAFETY STANDARDS

- Standard features: base pedestal, threaded delivery counterflange, guide tube supports
- **10 m** long power cable
- Float switch for single-phase versions

EN 60034-1
IEC 60034-1
CEI 2-3



CERTIFICATIONS



INSTALLATION AND USE

PMC pumps, made from heavy gauge cast iron offering exceptional sturdiness and abrasion resistance, come equipped with a DOUBLE-CHANNEL stainless steel impeller and are capable of pumping liquids containing short fibred suspended solids. They are ideal for pumping **sewage, waste water, water mixed with mud, groundwater and surface water** in locations such as apartment blocks, public buildings, factories, tower garages, underground car parks and cleaning areas, etc.

PATENTS - TRADE MARKS - MODELS

- Registered Community Design n° 342159-0017

OPTIONALS AVAILABLE ON REQUEST

- QES control box for three-phase pumps
- Single-phase pumps without float switch
- Other voltages or 60 Hz frequency

GUARANTEE

2 years subject to terms and conditions

► For the following versions the built-in thermal overload protector must be connected to the control box in order for the guarantee to be considered valid:

- | | |
|---------------------|-------------------------------------|
| single-phase | three-phase |
| – PMCm 30/50 - HP 3 | – PMC 15-20-30-40/50 - HP 1.5-2-3-4 |
| – PMCm 30/70 - HP 3 | – PMC 30-40/70 - HP 3-4 |

CHARACTERISTIC CURVES AND PERFORMANCE DATA

50 Hz n= 2900 1/min

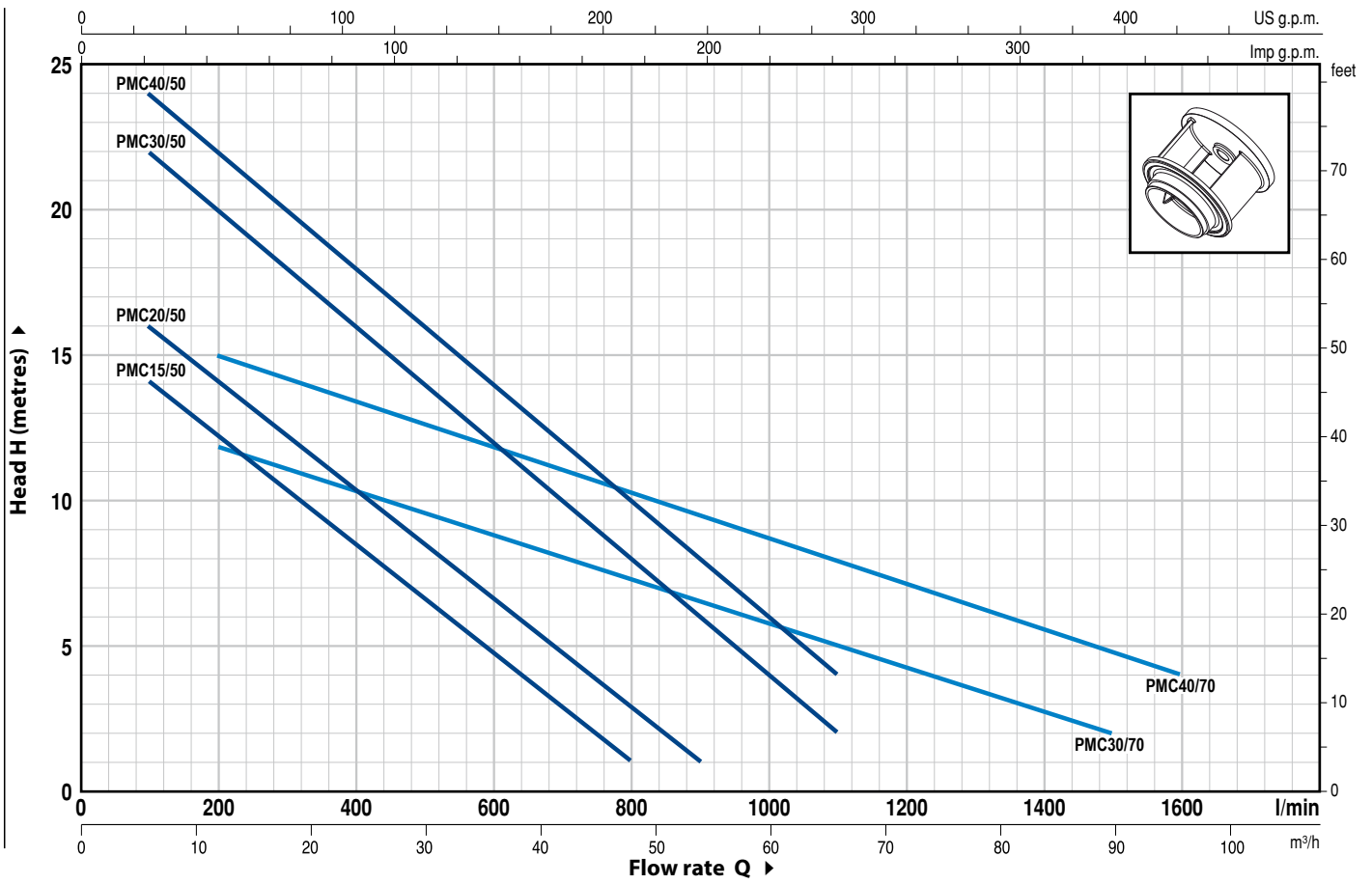

MODEL		POWER		Q	Flow rate																
Single-phase	Three-phase	kW	HP		m³/h	0	6	12	18	24	30	36	42	48	54	60	66	72	84	96	
PMCm 15/50	PMC 15/50	1.1	1.5	H metres	0	100	200	300	400	500	600	700	800	900	1000	1100	1200	1400	1600		
PMCm 20/50	PMC 20/50	1.5	2		16	14	12.5	10.5	8.5	6.5	4.5	3	1								
PMCm 30/50	PMC 30/50	2.2	3		18	16	14	12.5	10.5	8.5	6.5	5	3	1							
-	PMC 40/50	3	4		24	22	20	18	16	14	12	10	8	6	4	2					
PMCm 30/70	PMC 30/70	2.2	3		25	24	22	20	18	16	14	12	10	8	6	4					
-	PMC 40/70	3	4		13	-	12	11	10.5	9.5	8.5	8	7.5	6.5	6	5	4.5	3	2		
					17	-	15	14	13.5	12.5	12	11	10.5	9.5	8.5	8	7	5.5	4		

Q = Flow rate H = Total manometric head

Tolerance of characteristic curves in compliance with EN ISO 9906 App. A.

PMC "DOUBLE-CHANNEL"

POS. CONSTRUCTION CHARACTERISTICS

1	PUMP BODY	Cast iron, complete with flanged ports	
2	SUCTION PLATE	Cast iron	
3	BASE PEDESTAL	Cast iron	
4	CONTERFLANGE	Steel, complete with threaded ports in compliance with ISO 228/1	
5	GUIDE TUBE SUPPORTS	Cast iron	
6	IMPELLER	Stainless steel AISI 304 DOUBLE-CHANNEL type	
7	MOTOR CASING	Cast iron	
8	MOTOR CASING PLATE	Cast iron	
9	MOTOR SHAFT	Stainless steel AISI 431	
10	TWO MECHANICAL SEALS SEPARATED BY AN OIL CHAMBER		
	Seal	Shaft	Materials
	<i>Model</i>	<i>Diameter</i>	<i>Stationary ring</i> <i>Rotational ring</i> <i>Elastomer</i>
	STA-20	Ø 20 mm	Ceramic Graphite NBR
	STA-19	Ø 19 mm	Silicon carbide Silicon carbide NBR
11	BEARINGS	6304 ZZ - C3 / 6304 ZZ - C3	

POS. CONSTRUCTION CHARACTERISTICS

12 CAPACITOR

<i>Pump</i>	<i>Capacitance</i>
<i>Single-phase</i>	<i>(230 V or 240 V)</i>
PMcM 15/50	31.5 µF 450 VL
PMcM 20/50	50 µF 450 VL
PMcM 30/50-70	60 µF 450 VL

13 ELECTRIC MOTOR

PMcM 15-20: single-phase 230 V - 50 Hz with thermal overload protector built-in to the winding.

⇒ **PMcM 30:** single-phase 230 V - 50 Hz with motor protector built-in to the winding to be connected to the control box

⇒ **PMC:** three-phase 400 V - 50 Hz with motor protector built-in to the winding to be connected to the control box

– Insulation: F class

– Protection: IP X8

14 POWER CABLE

10 m long "H07 RN-F" cable

15 CONTROL BOX foe PMcM 15-20

(only for single-phase versions)

Complete with capacitor and manual reset motor protector

16 CONTROL BOX for PMcM 30

(only for single-phase versions)

QES 300 MONO series

17 FLOAT SWITCH

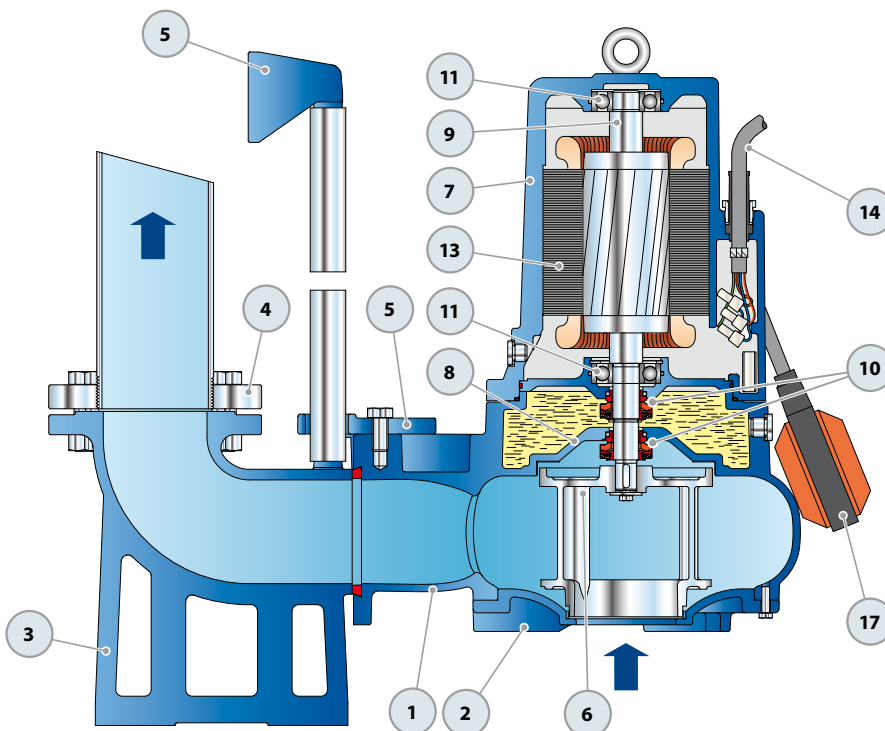

Standard features

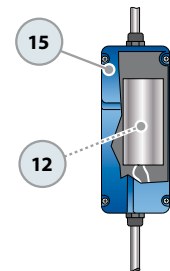

Control box for PMcM 15-20 (HP 1.5-2.0)
(only for single-phase versions)

Standard features

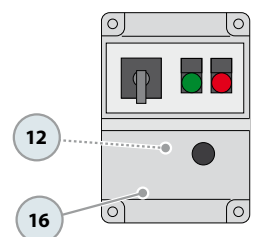

Control box for PMcM 30 (HP 3.0)
(only for single-phase versions)

DIMENSIONS AND WEIGHT

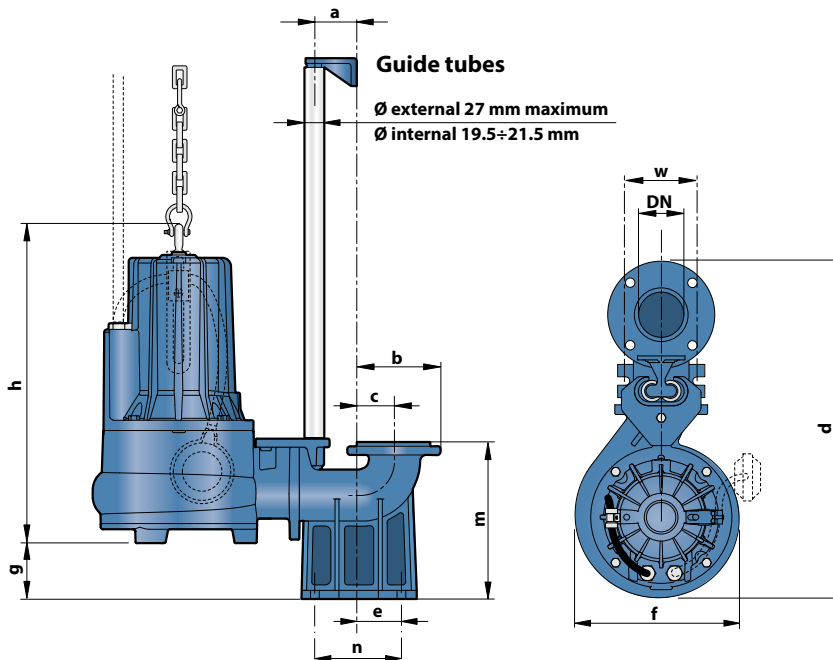

Typical installation

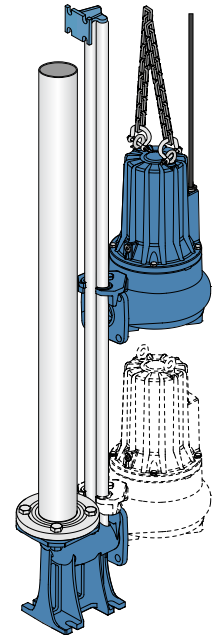

MODEL		PORT	solids passage	DIMENSIONS mm											kg*	
Single-phase	Three-phase	DN		a	b	c	d	e	f	g	h	m	n	w	1~	3~
PMcM 15/50	PMC 15/50	2½"	Ø 50 mm	60	116	51	490	62	248	52	442	198	120	72	47.2	45.9
PMcM 20/50	PMC 20/50										457/442				48.2	46.9
PMcM 30/50	PMC 30/50										457				52.2	49.1
-	PMC 40/50										-				-	52.7
PMcM 30/70	PMC 30/70	3"	Ø 70 mm	60	150	70	570	85	268	92	472/458	255	130	112	62.6	59.3
-	PMC 40/70										472				-	62.9

(*weight includes counterflanges)

ABSORPTION

MODEL	VOLTAGE (single-phase)	
Single-phase	230 V	240 V
PMcM 15/50	9.0 A	9.0 A
PMcM 20/50	10.5 A	10.5 A
PMcM 30/50	15.2 A	15.2 A
PMcM 30/70	15.2 A	15.2 A

MODEL	VOLTAGE (three-phase)					
Three-phase	230 V	400 V	690 V	240 V	415 V	720 V
PMC 15/50	6.1 A	3.5 A	2 A	6.1 A	3.5 A	2.0 A
PMC 20/50	7.4 A	4.3 A	2.5 A	7.4 A	4.3 A	2.5 A
PMC 30/50	9.9 A	5.7 A	3.3 A	9.9 A	5.7 A	3.3 A
PMC 40/50	13.5 A	7.8 A	4.5 A	13.5 A	7.8 A	4.5 A
PMC 30/70	10.2 A	5.9 A	3.4 A	10.2 A	5.9 A	3.4 A
PMC 40/70	13.5 A	7.8 A	4.5 A	13.5 A	7.8 A	4.5 A

PALLETIZATION

MODEL		GROUPAGE / CONTAINER			
Single-phase	Three-phase	n° pumps	H (mm)	kg	
PMcM 15/50	PMC 15/50	24	1751	1151	1119
PMcM 20/50	PMC 20/50	24	1751	1175	1143
PMcM 30/50	PMC 30/50	24	1751	1275	1196
-	PMC 40/50	12	1751	-	1283
PMcM 30/70	PMC 30/70	12	1304	769	729
-	PMC 30/70	12	1304	-	772

