



Pompa Pedrollo F50/250B (400V)

Cena brutto	12 515,00 zł
Cena netto	10 174,80 zł
Dostępność	Dostępny
Czas wysyłki	10 dni
Producent	PEDROLLO

Opis produktu



F50/250B - pompy stosowane do zaopatrzenia w wodę, zestawów czyszczących, podwyższania ciśnienia, zestawów przeciwpożarowych, nawadniania, zastosowań przemysłowych, obiegu wody w zestawach klimatyzacyjnych, zastosowaniach rolniczych.

Pompy muszą być instalowane w zamkniętych miejscach lub przynajmniej chronione przed niekorzystnymi warunkami pogodowymi.



Dane techniczne:

- Napięcie zasilania - **400 V (15 kW)**
- Wydajność maksymalna - **1000 l/min (60 m³/h)**
- Wydajność podnoszenia maks. - **72 m (7,2 bar)**
- Max. ciśnienie w obudowie pompy - **10 bar**
- Wysokość ssania maks. - **7 m**
- Zakres temperatur medium - **-10 °C and +90 °C**
- Temperatura otoczenia - **od -10 °C do +40 °C**
- Przyłącze - **Króciec ssący DN65, króciec tłoczny DN50**
- Waga - **121 kg**

Zastosowanie:

- Systemy zaopatrzenia w wodę
- Zestawy przeciwpożarowe
- Systemy klimatyzacji
- Systemy mycia
- Systemy chłodzenia



- Systemy ciśnieniowe
- pompy irygacyjne

Dane:

MODEL	MOC (P2)		Q	0	18	24	30	36	42	48	54	60
	kW	HP		0	300	400	500	600	700	800	900	1000
Trójfazowa												
F 50/250D	9.2	12.5	H metry	51	51	49	47	44	41	37	32	
F 50/250C	11	15		59	59	58	57	54	51	47	42	
F 50/250B	15	20		72	72	71	70	69	67	65	62	59
F 50/250A	18.5	25		85	85	84	83	82	80	78	76	73
F 50/250AR	22	30		95	95	94	93	92	90	88	86	83

Q = Wydajność H = Wysokość podnoszenia HS = Wysokość ssania

Tolerancja charakterystyk wg EN ISO 9906 Grade 3B.

F50/250



CHARAKTERYSTYKA POMP

50 Hz n= 2900 min⁻¹ HS= 0 m

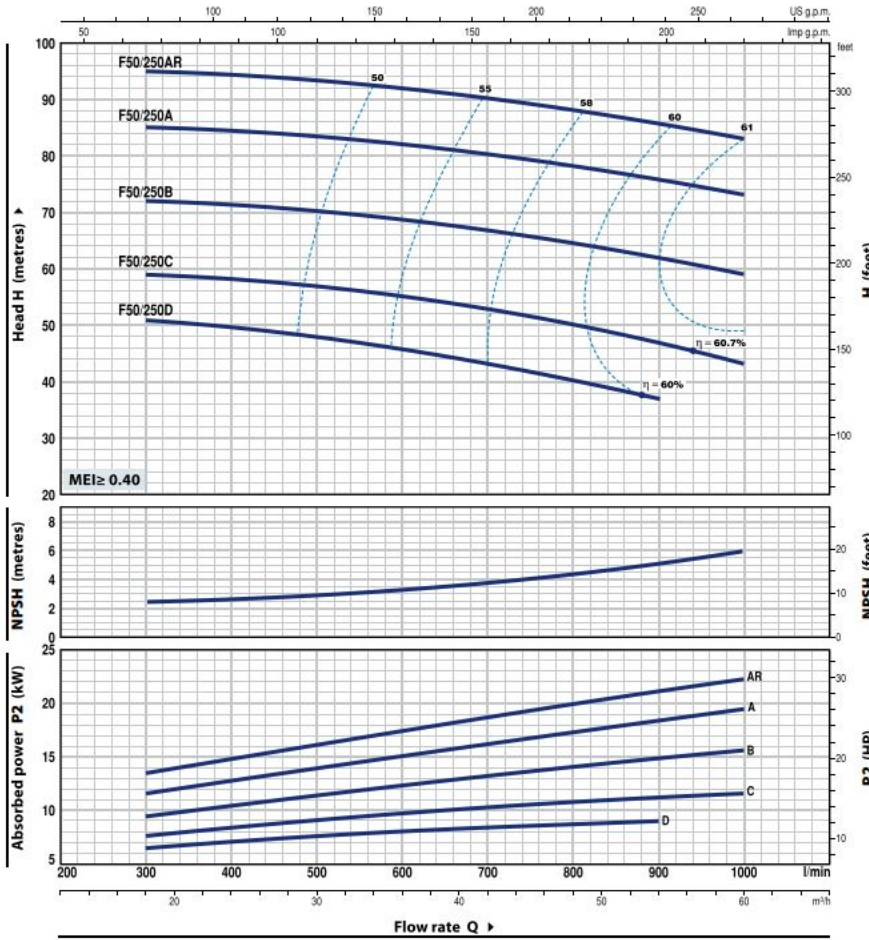

WYMIARY I WAGA

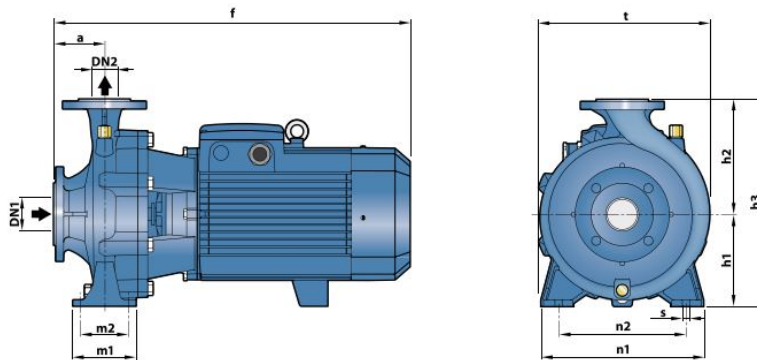

MODEL		WYMIARY mm													kg											
Jednofazowa	Trójfazowa	DN1	DN2	a	f	h1	h2	h3	t	n1	n2	m1	m2	s	1~	3~										
Fm 32/160C	F 32/160C	50	32	80	419	132	160	292	240	245	190	100	70	14	32.6	32.3										
Fm 32/160B	F 32/160B				448/432										42.3	35.2										
-	F 32/160A				448										-	38.7										
-	F 32/200C				469										-	46.3										
-	F 32/200B				515										-	51.8										
-	F 32/200A				515										160	180	340	273	95	-	56.9					
-	F 32/200BH			469	-	42.0																				
-	F 32/200AH			469	-	45.8																				
-	F 32/250C			100	70	606	180	225	405	325	320	250	125		95	-	105.5									
-	F 32/250B															701	-	103.2								
-	F 32/250A															701	-	121.0								
Fm 40/125C	F 40/125C															65	40	80	421	112	140	252	244	210	160	100
Fm 40/125B	F 40/125B	441	33.0											32.4												
-	F 40/125A	439	-											32.6												
Fm 40/160C	F 40/160C	448	38.3	33.4																						
-	F 40/160B	448	-	38.9																						
-	F 40/160A	465	-	43.6																						
-	F 40/200B	535	160	180	340	277	265	212	265	212	100	70	-	53.0												
-	F 40/200A												535	-	59.0											
-	F 40/250C												606	180	225			405	329	320	250	125	95	-	104.0	
-	F 40/250B																							701	-	104.0
-	F 40/250A																							701	-	120.0
Fm 50/125C	F 50/125C																							465/451	36.8	35.1
-	F 50/125B	465	-	38.5																						
-	F 50/125A	484	-	42.8																						
-	F 50/160C	489	-	47.3																						
-	F 50/160B	535	180	340	273	265	212	100	70	-	52.8															
-	F 50/160A									535	-	57.6														
-	F 50/200C									616	160	200	360	316.5	265	212	-	100.0								
-	F 50/200B									711	-	115.0														
-	F 50/200A									743	-	127.2														
-	F 50/200AR									743	-	141.0														
-	F 50/250D	605	180	225	405	333	320	250	-	104.2																
-	F 50/250C								701	-	105.0															
-	F 50/250B								701	-	121.0															
-	F 50/250A								733	-	134.2															
-	F 50/250AR								733	-	147.0															
-	F 65/125C								511	-	53.2															
-	F 65/125B	557	160	180	340	292	280	212	125	95	-	58.3														
-	F 65/125A										557	-	63.0													
-	F 65/160C										620	200	360	295	-	98.5										
-	F 65/160B										716	-	100.2													
-	F 65/160A										718	-	114.0													
-	F 65/200B										718	-	119.3													
-	F 65/200A	751	180	225	405	336	320	250	-	132.1																
-	F 65/200AR								751	-	145.3															
-	F 80/160D								652	-	103.1															
-	F 80/160C								747	-	120.0															
-	F 80/160B								779	-	133.8															
-	F 80/160A								779	-	144.0															
-	F 100/160C	760	200	280	480	382	360	280	160	120	18	-	141.2													
-	F 100/160B											790	-	150.3												
-	F 100/160A											790	-	164.0												

Pozostałe modele :

DANE O WYDAJNOŚCI

50 Hz n= 2900 min⁻¹

MODEL	MOC (P ₂)		▲	WYDAJNOŚĆ	
	kW	HP		Q l/min	H metry
F 32/160C	1.5	2	IE3	100 - 350	24 - 14
F 32/160B	2.2	3		100 - 400	30 - 17
F 32/160A	3	4		100 - 450	37 - 24
F 32/200C	4	5.5		100 - 450	44 - 31.5
F 32/200B	5.5	7.5		100 - 500	51 - 36
F 32/200A	7.5	10		100 - 500	57 - 44
F 32/200BH	3	4		100 - 300	45 - 37
F 32/200AH	4	5.5		100 - 320	55 - 44
F 32/250C	9.2	12.5		100 - 450	75 - 60
F 32/250B	11	15		100 - 500	87 - 70
F 32/250A	15	20		100 - 500	97 - 80
F 40/125C	1.1	1.5		100 - 550	16 - 6
F 40/125B	1.5	2		100 - 600	20.5 - 9
F 40/125A	2.2	3		100 - 700	26 - 10
F 40/160C	2.2	3		100 - 600	27 - 14
F 40/160B	3	4		100 - 600	32 - 20
F 40/160A	4	5.5	100 - 700	38 - 20	
F 40/200B	5.5	7.5	100 - 700	47 - 28	
F 40/200A	7.5	10	100 - 700	55 - 41	
F 40/250C	9.2	12.5	100 - 700	64 - 47	
F 40/250B	11	15	100 - 700	71 - 55	
F 40/250A	15	20	100 - 700	88 - 72	
F 50/125C	2.2	3	300 - 1200	17.5 - 6	
F 50/125B	3	4	300 - 1200	20.7 - 9	
F 50/125A	4	5.5	300 - 1200	23.5 - 13	
F 50/160C	4	5.5	300 - 1000	27 - 16	
F 50/160B	5.5	7.5	300 - 1100	32 - 21	
F 50/160A	7.5	10	300 - 1100	37 - 27	
F 50/200C	11	15	400 - 1700	44 - 30	
F 50/200B	15	20	400 - 1700	52 - 38	
F 50/200A	18.5	25	400 - 1800	61 - 45	
F 50/200AR	22	30	400 - 1800	69 - 53	
F 50/250D	9.2	12.5	300 - 900	51 - 32	
F 50/250C	11	15	300 - 900	59 - 42	
F 50/250B	15	20	300 - 1000	72 - 59	
F 50/250A	18.5	25	300 - 1000	85 - 73	
F 50/250AR	22	30	300 - 1000	95 - 83	

MODEL	MOC (P ₂)		▲	WYDAJNOŚĆ	
	kW	HP		Q l/min	H metry
F 65/125C	4	5.5	IE3	600 - 1800	16 - 11
F 65/125B	5.5	7.5		600 - 2000	18 - 13
F 65/125A	7.5	10		600 - 2200	23 - 18
F 65/160C	9.2	12.5		600 - 2200	32 - 22
F 65/160B	11	15		600 - 2400	36.5 - 23
F 65/160A	15	20		600 - 2400	40.5 - 28
F 65/200B	15	20		200 - 2400	44 - 30.5
F 65/200A	18.5	25		200 - 2500	50 - 36.5
F 65/200AR	22	30		200 - 2600	57 - 42
F 65/250C	30	40		400 - 2350	76 - 53
F 65/250B	37	50		400 - 2500	87 - 62
F 65/250A	45	60		400 - 2600	95 - 68
F 80/160D	11	15		500 - 4000	25 - 10
F 80/160C	15	20		500 - 4000	30 - 15
F 80/160B	18.5	25		500 - 4000	35 - 20
F 80/160A	22	30		500 - 4000	40 - 25
F 80/200B	30	40	500 - 3650	56 - 34.5	
F 80/200A	37	50	500 - 3900	62 - 40	
F 80/250B	45	60	600 - 3600	77 - 54	
F 80/250A	55	75	600 - 3900	88.5 - 60	
F 100/160C	15	20	1000 - 5000	30 - 12	
F 100/160B	18.5	25	1000 - 5200	34 - 14.5	
F 100/160A	22	30	1000 - 5500	38 - 17.5	
F 100/200C	30	40	833 - 4650	51 - 28	
F 100/200B	37	50	833 - 4900	57 - 33	
F 100/200A	45	60	833 - 5250	63 - 38	
F 100/250B	55	75	800 - 5150	75 - 48	
F 100/250A	75	100	800 - 5750	89 - 58	

Q = Wydajność

H = Wysokość podnoszenia

Tolerancja charakterystyk wg EN ISO 9906 Grade 3B.

▲ Klasa wydajności silnika trójfazowego (IEC 60034-30-1)

DANE WYDAJNOŚCIOWE

50 Hz n= 2900 min⁻¹

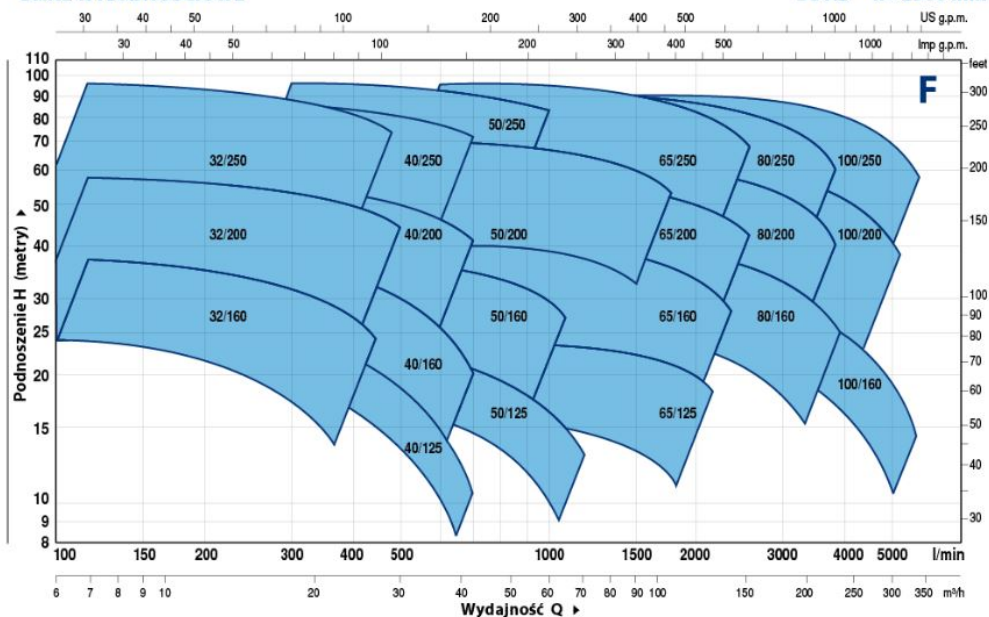

>>>więcej



więcej

